

VILLAGE OF NORTH SYRACUSE

Regular Board Meeting

Thursday, March 26th, 2026 at 5:30 P.M.

North Syracuse Community Center

700 South Bay Road, North Syracuse, NY

"YOUTUBE Livestreamed"

AGENDA "1st Floor"

1. Call to order
2. Pledge to the Flag
3. Roll Call

Public Hearing #1 at 5:28 PM: Please take Notice that a public hearing will be held by the Board of Trustees of the Village of North Syracuse on the 26th Day of March at 5:28 PM regarding Community Input for Application and Update to our 5 Year Plan.

Public Hearing #2 at 5:29 PM: Please take notice that a public hearing will be held by the Board of Trustees of the Village of North Syracuse on the 26th Day of March at 5:29 PM regarding Passing a Tax Levy exceeding the 2% Tax Limit for FY 2026/2027.

4. Accept the Resignation of Mayor Gary Butterfield Effective 3/13/2026 - Motion to Appoint New Mayor
5. Swearing in of New Recruit Police Officers Justin Davis & Cameron Bragman
6. Minute Approval – March 12th, 2026
7. Abstract Approval
8. Budget Transfer:
9. Citizens' Voice (please limit your topic to 3 minutes or less)

OLD BUSINESS:

- a. Review of Estoppel Notice for Proposed Fire Truck #1 – Expiration of Estoppel 4/12/26, and establish Bonding Term Length (7/10/12 – years financing)
- b. Revisit Town of Cicero Fire Service Contract, motion to have acting mayor sign contract

NEW BUSINESS:

- a. Accept the resignation of DPW Employee Christian Johnstone – Effective 3/25/2026
- b. Discuss Open CDL Maintenance and Laborer 1 openings with DPW
- c. Discuss Schedule of Public Hearings related to 2026/2027 Budget

- | | |
|-----------------------------|--|
| 10. Attorney Report | 11. Trustee's Report |
| 11. Engineer Report | 12. Deputy Mayor's Report |
| 12. Department Heads Report | 13. Adjourn to Exec. Session (If Nec.) |

VILLAGE OF NORTH SYRACUSE BOARD OF TRUSTEES

Unless otherwise specified, all items on tonight's agenda are Type II actions for purposes of SEQR.



Via email

April 11, 2025

Mr. Michael LaFlair
Onondaga County Community Development
11th Floor John H. Mulroy Civic Center
Syracuse, New York 13202

**RE: Village of North Syracuse
2025 Community Development Funding
Updated 5 Year Plan
CHA Project No.: 22016.1082**

Dear Mr. La Flair:

CHA Consulting, Inc., Engineer for the Village of North Syracuse, is pleased to submit an updated Five-Year Consolidated Plan for 2025. The Plan has been emailed to michaellaflair@ongov.net.

If you should have any questions or require additional information, please feel free to contact me at 315-471-3920 or afranco@chasolutions.com.

Very truly yours,

A handwritten signature in blue ink that reads "Amy Franco". The signature is written in a cursive, flowing style.

Amy Franco, RLA
Municipal Engineer Representative

AMF
Enclosure
cc (via email):
Mayor Gary Butterfield
Board of Trustees
Dianne Kufel, Village Clerk-Treasurer

V:\Projects\SNY\22016\Data\Other\1082 - 2025 OCCD Wells Ave E\5 Year Plan\Backup\2025-5Yr Submission-letter.docxv

CONSOLIDATED FIVE YEAR PLAN
2025 ONONDAGA COUNTY COMMUNITY DEVELOPMENT

For:

CAPITAL IMPROVEMENT PROJECTS

April 2025

Prepared For:



Village of North Syracuse
600 South Bay Road
North Syracuse, NY 13212
Onondaga County, New York

Prepared By:



One Park Place
300 South State Street Suite 600
Syracuse, New York 13202

CHA Project Number: 22016.1082



1. WELLS AVENUE EAST SIDEWALK PROJECT

Wells Avenue East is centrally located within the Village connecting South Main Street (US Route 11) and South Bay Road (CR 208). This section of the Village serves not only the businesses and residences on Wells Ave. E., but it also serves as a connecting corridor between S. Main Street and S. Bay Rd. and to destinations to the east and west of these major thoroughfares. The sidewalk replacement project would focus on removing and reinstalling sidewalk along the north side of Wells Avenue East between South Main Street (US Route 11) and South Bay Road (CR 208). Removals include grass, 270+/- linear feet of driveway sections, and 465+/- linear feet of three feet (3') heaved and cracked concrete sidewalk. Installation includes five feet (5') wide sidewalks for its entirety with approximately 465+/- linear feet of concrete sidewalk (4" depth), 270+/- linear feet of concrete sidewalk through driveways (6" depth), three (3) cast iron embedded detectable warning units, and one (1) curb ramp. The detectable warning and curb ramp will be installed on the east end by the Village Hall. Disturbed grass areas impacted by the work will receive topsoil and seed.

The estimated cost of this total project is approximately \$52,142.

2. KENNEDY PARK IMPROVEMENT PROJECT

Kennedy Park is located at 114 Grove Street, which is in the northeastern portion of the Village. The site currently consists of an outdoor swimming pool with a restroom and storage building, picnic/pavilion facilities, playground and sand volleyball court on 2.42± acres. The projects that the Village would like to complete are to update and reconfigure the main entrance to the pool and the restroom building and add changing room and a family bathroom. Additions include basketball poles and play equipment for ages 13+. A major goal of this Park is to ultimately add a splash pad, which due to cost would be a stand-alone project and would include multiple funding opportunities (est. cost \$480,000).

The estimated cost of this project is approximately \$212,280.

3. LONERGAN PARK IMPROVEMENT PROJECT

Loneragan Park is located along the west side of South Main Street within the southwest section of the Village on 7.41± acres. This park consists of a Little League field with a batting cage and lighting for night games, two playgrounds, a restroom and storage facility, a gazebo and a seating area. Its location within the Village makes it easily accessible from the adjacent residences, apartments, and businesses. Activities include weekly "Concerts in the Park" during the summer that attract 250± people, a 100± youth 6-week summer day camp, and Little League games and practices occur 6 days per week during the summer and several times per week in the fall. The proposed improvements include a new electric sign, planting 20 trees throughout the Park, add cover to the stage area on the gazebo, and install a 1300 linear feet stonedust walking trail around the perimeter of the park for visitors and dog walkers.

The estimated cost of this total project is approximately \$63,700.



4. CENTERVILLE PARK IMPROVEMENT PROJECT

Centerville Park is located along the northbound side of South Bay Road between Wells Avenue East and Centerville Place on 2.31± acres. The site currently consists of a parking area, playground, basketball court, sledding hill, pavilion, and lawn area. The park received Community Development and Save the Rain funds in 2013 to improve drainage issues, court resurfacing, reduction of impervious area, walkway resurfacing, parking area resurfacing, and tree plantings. With this work, the Village's in-kind services involved installing a pavilion. With the amount of use this park is now receiving between the park activities and pavilion rentals, bathroom facilities are needed. This requires users to leave the park if they need to use the restroom facilities which might discourage park use, especially for families with young children. At times of peak usage, the Village Parks and Recreation Department utilizes a portable toilet. Adding restroom facilities for park users would require tying into the existing Village sewage system located across the South Bay Road. The Village would also like to add additional playground equipment for 13+ age group, as well as new basketball poles, backboards, and baskets.

The estimated cost of this total project is approximately \$235,300.

5. SLEETH MILL PARK IMPROVEMENT PROJECT

Sleeth Mill Park is located at 200 Hamilton Rd and can be accessed from Hamilton Road on the northeastern side of the Village. Constructed as part of the Sleeth Mill Circle development, the park consists of 25.97± acres and includes a wetland area trail and observation deck. A local boy scout troop has been instrumental in building a log bridge and the observation deck within the park. The Village is looking to re-mulch the trail, provide path maintenance, and install drainage improvements. The Village would like to also provide signage and additional amenities for mountain biking, trail running, and cross-country skiing.

The estimated cost of this total project is approximately \$63,500.

6. WALKABLE VILLAGE

Around 2011 a Village resident, in coordination with the Village Parks and Recreation Department, put together a walking plan for the entire Village. The plan was developed to link all of the Village Parks and to make a "Walkable Village." A physical map was created that included a map of the streets and the 12 parks' proximity to one another, as well as a chart with a numbered list of the name of the parks, if there was distance marker, if there was a bench, and the points of interest within the park. A wooden post with the name of the park and the distance and a directional arrow to the next park, were also installed at each park. This plan has been successful, and the Village would like to increase the visibility of the Village's walkability with the addition of all the parks within the Village, add more distance markers, and add building mounted signage to the larger parks to show the overall map and the distances.

The estimated cost of this total project is approximately \$46,500.



7. VILLAGE-WIDE STREET DRAINAGE AND ROADWAY IMPROVEMENTS

The proposed project includes multiple phases of drainage and roadway improvements within the Village. Specifically, the streets are Centerville Place, Maxwell Avenue, and Watson Road within the central and northern sections of the Village. These areas have been determined by the Village as areas of concern due to the deteriorating and degrading condition that is needed to provide a safe travel way within each neighborhood. The improvements that are needed, and are identified below:

- a. Watson Rd. – drainage issues along entire road, 2200 linear feet of deteriorated roadway and a lack of right-of-way drainage. Proposed improvements include milling and overlaying the 7500 square yards of asphalt roadway, installing 4400 linear feet of 4" perforated underdrains, and 420 square yards of asphalt driveway restoration with underdrain.
- b. Maxwell Avenue – drainage issues due to lack of storm system, 2020 linear feet of deteriorated roadway and a lack of right-of-way drainage. Proposed improvements include milling and overlaying the 6750 square yards of asphalt roadway, installing 4040 linear feet of 4" perforated underdrains, and 520 square yards of asphalt driveway restoration with underdrain.
- c. Centerville Place – insufficient capacity of storm system, 3000 linear feet of drainage improvements along both sides of the street and connecting to the existing storm system with new catch basins, piping, and 3500 square yards of asphalt roadway restoration.

The lack of a defined roadway edge and proper drainage courses have minimized the available right-of-way that is used for two-way vehicular movement, on-street parking, snow removal, and pedestrian movement. These conditions are unsafe and detract from the quality of life for these residents. The proposed project will eliminate stormwater ponding and the lack of a drainage system in this area that contribute to excess volume within the roadway and create overland flow across roadways. By providing a way for the stormwater to infiltrate the ground the Village is preventing the stormwater from entering a standard piped system and eliminating sediment and contaminants from entering the system. Installing the appropriate drainage pipes along the roadway eliminates stormwater from ponding on the roadway, which creates unnecessary aging and deterioration of the asphalt and subbase, increases roadway maintenance, restricts travel-ways, and minimizes available on-street parking.

The estimated cost of this total project is approximately \$738,725, which would be phased based upon available monies.

8. ADDITIONAL PROJECTS TO BE CONSIDERED

- a. Street signs throughout the whole Village
- b. Decorative streetlights and underground power
- c. Pedestrian crossing signage with lights on both sides of the crosswalk across North Main Street between Watson Road and Shaver Avenue. The estimated cost of this project is approximately \$35,000
- d. Intersection improvements at Grove St., Van Mara Dr., Maxwell Ave., and Watson Rd. with S. Bay Rd.



VILLAGE OF NORTH SYRACUSE COMMUNITY DEVELOPMENT BLOCK GRANT 2025 ELIGIBLE AREAS

110.21

105

N. Main St. Pedestrian Crossing Signs

Kennedy Park

110.22

Wells Ave E

107

Sleeth Mill Park

Centerville Park

06

Lonergan Park

139

109

Legend

- CDBG Eligible Areas
- Census Tracts (2010)
- Block Groups (2010)

Low/Mod Income Data Source: 2011-2015 Census ACS Data

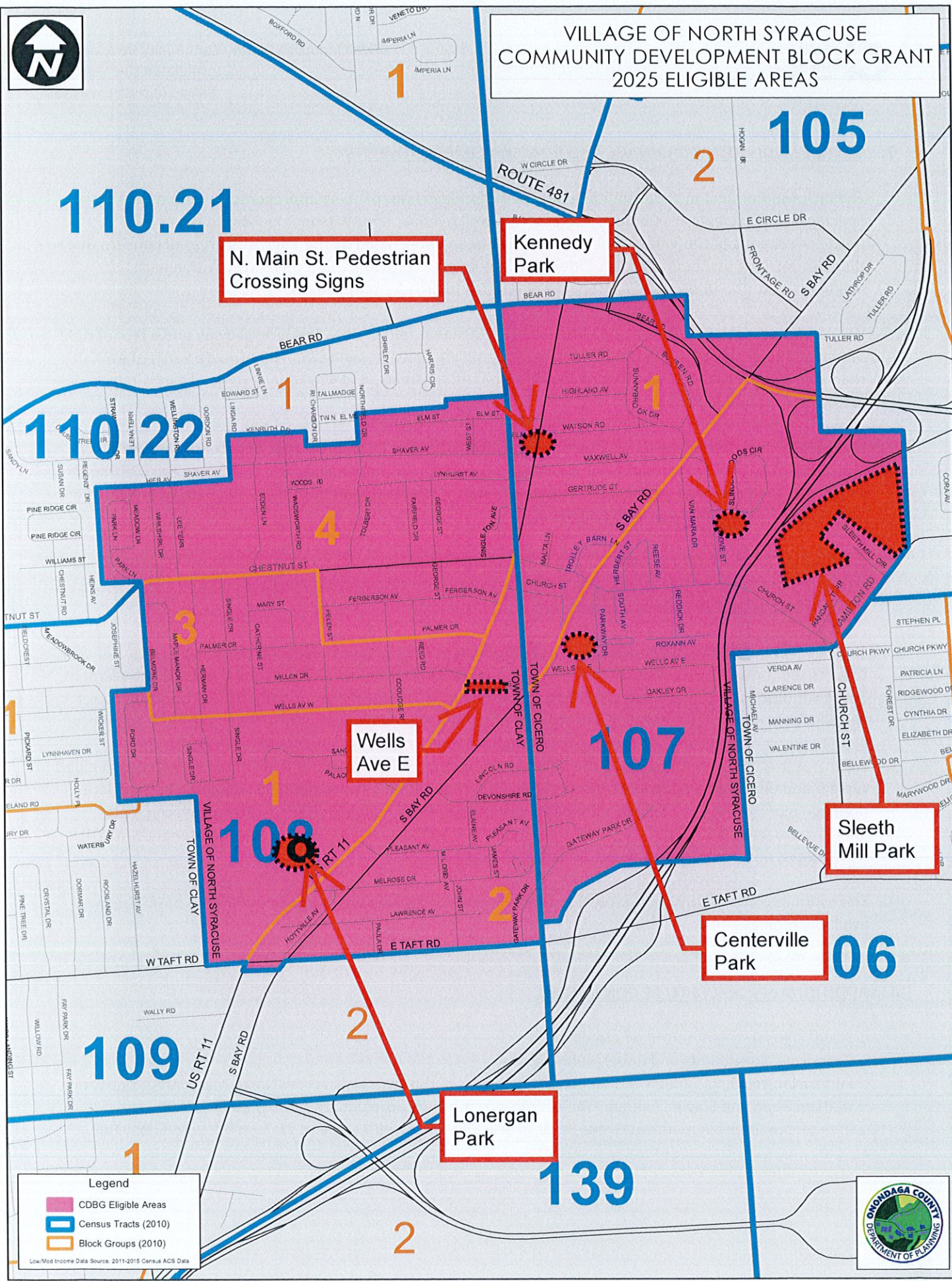



WELLS AVENUE EAST SIDEWALK PROJECT



Prepared By: CHA Consulting

NORTH SYRACUSE SIDEWALKS PRELIMINARY ESTIMATE						
NYS DOT ITEM	DESCRIPTION	UNIT		TOTAL	UNIT PRICE	AMOUNT
			WELLS AVE East			
203.02	UNCLASSIFIED EXCAVATION AND DISPOSAL	CY	122	122	\$ 40.00	\$ 4,880.00
304.12	SUBBASE COURSE, TYPE 2	CY	69	69	\$ 70.50	\$ 4,864.50
608.0101	CONCRETE SIDEWALKS AND DRIVEWAYS	CY	54	54	\$ 725.00	\$ 39,150.00
608.21000003	CAST IRON EMBEDDED DETECTABLE WARNING UNITS	SY	5	5	\$ 450.00	\$ 2,250.00
610.1601	TOPSOIL & SEED	SY	105	105	\$ 9.50	\$ 997.50
TOTAL ESTIMATE FOR CONSTRUCTION						\$ 52,142.00

2025 OCCD Block Grant
Wells Ave E Sidewalk Project
Village of North Syracuse

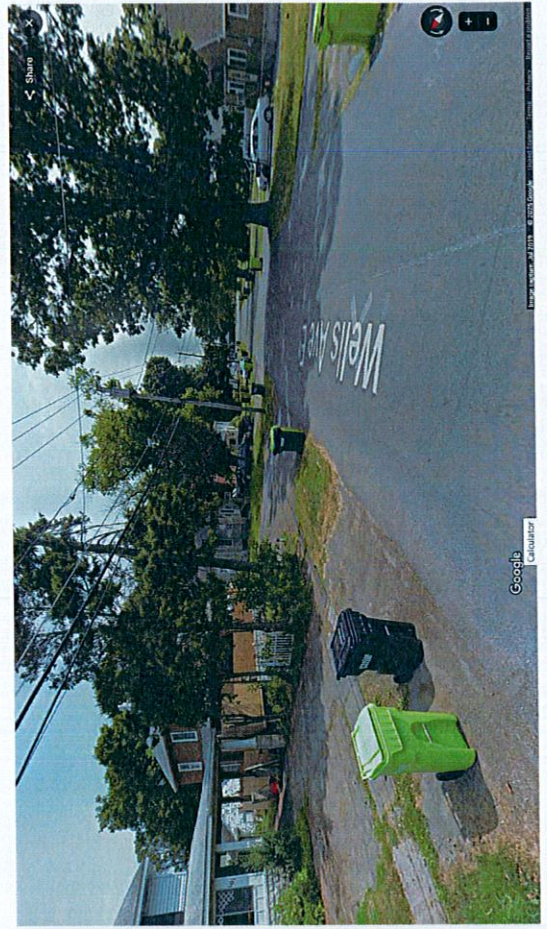
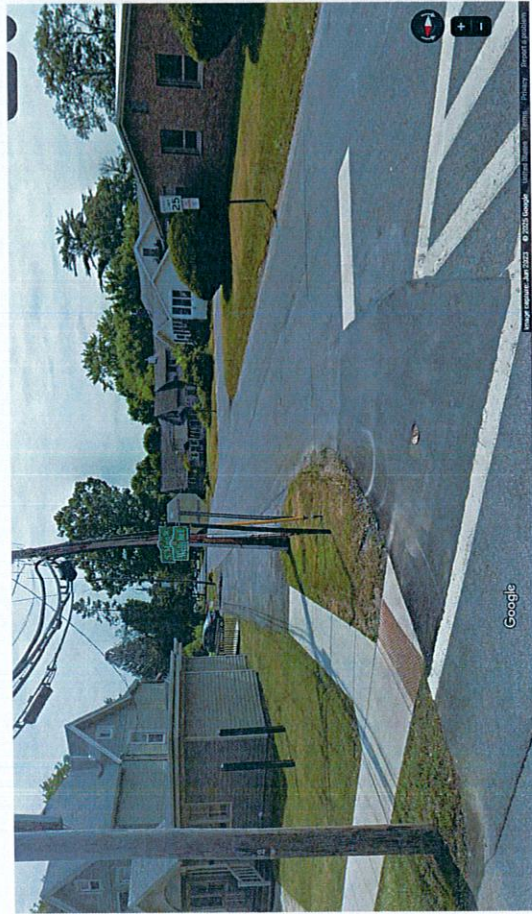

2025 OCCD Block Grant
Wells Ave E Sidewalk Project
Village of North Syracuse

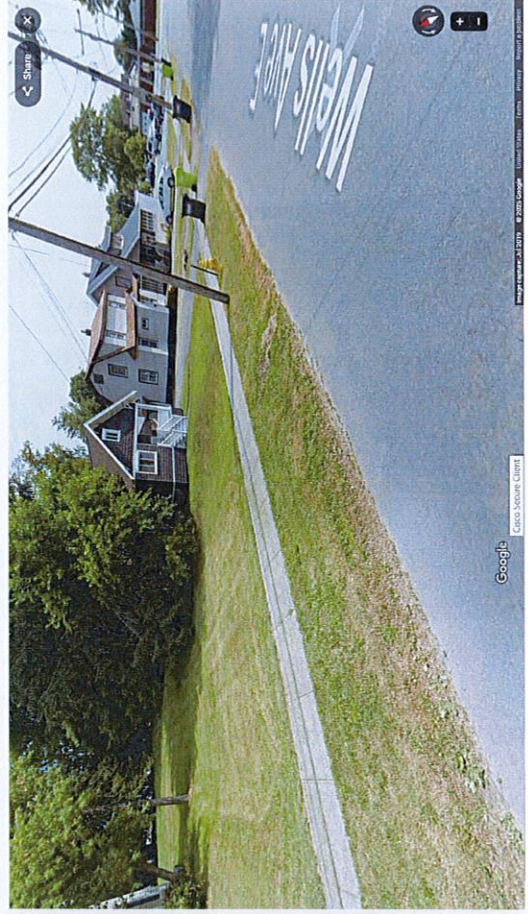
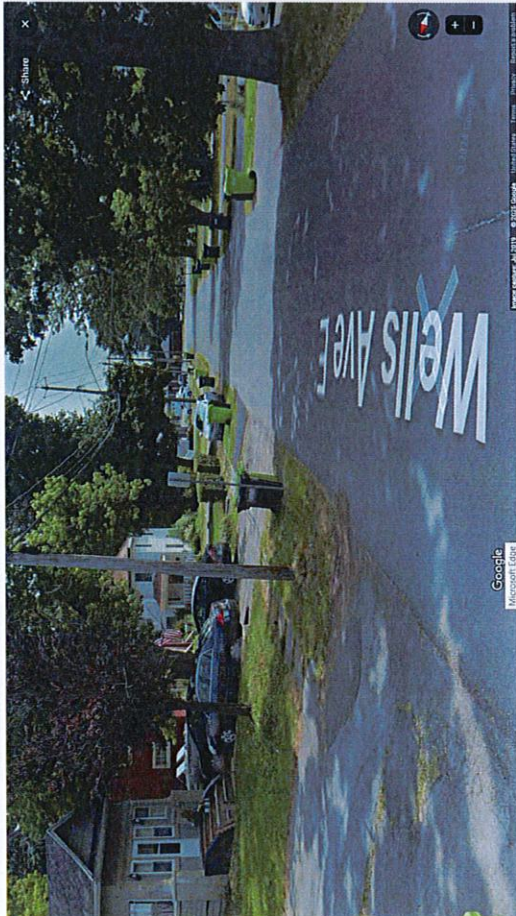
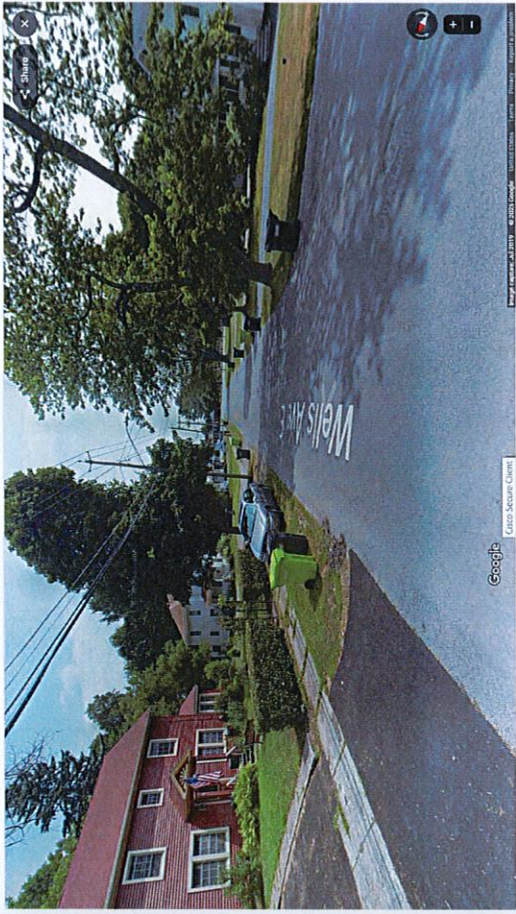

2025 OCCD Block Grant
Wells Ave E Sidewalk Project
Village of North Syracuse

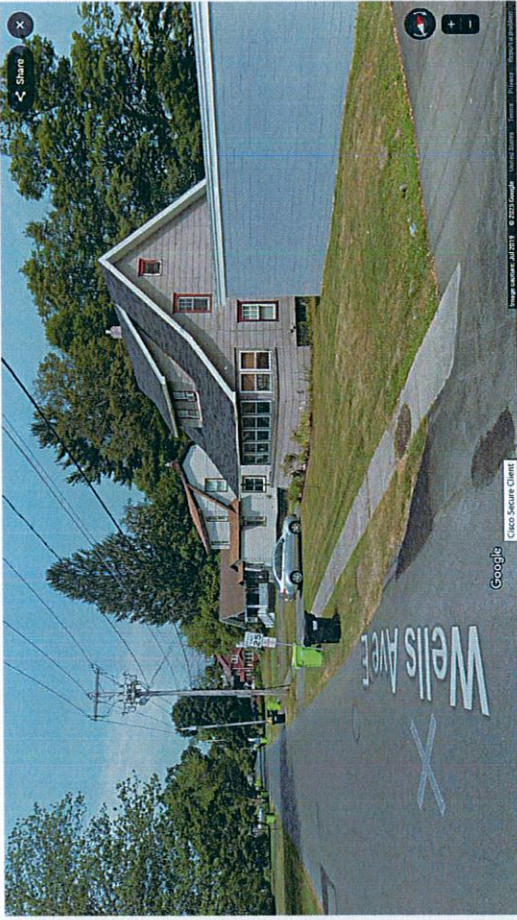



KENNEDY PARK IMPROVEMENT PROJECT

5 Year Plan
Kennedy Park Pool Area Renovation
Village of North Syracuse, NY



Exterior of pool area.

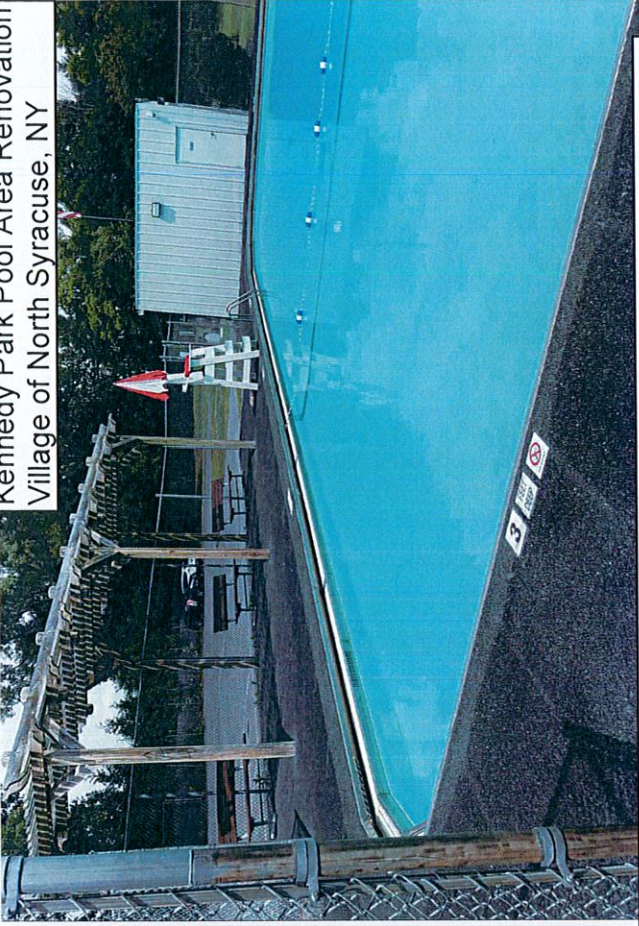

Interior of pool area.



Interior of pool area.

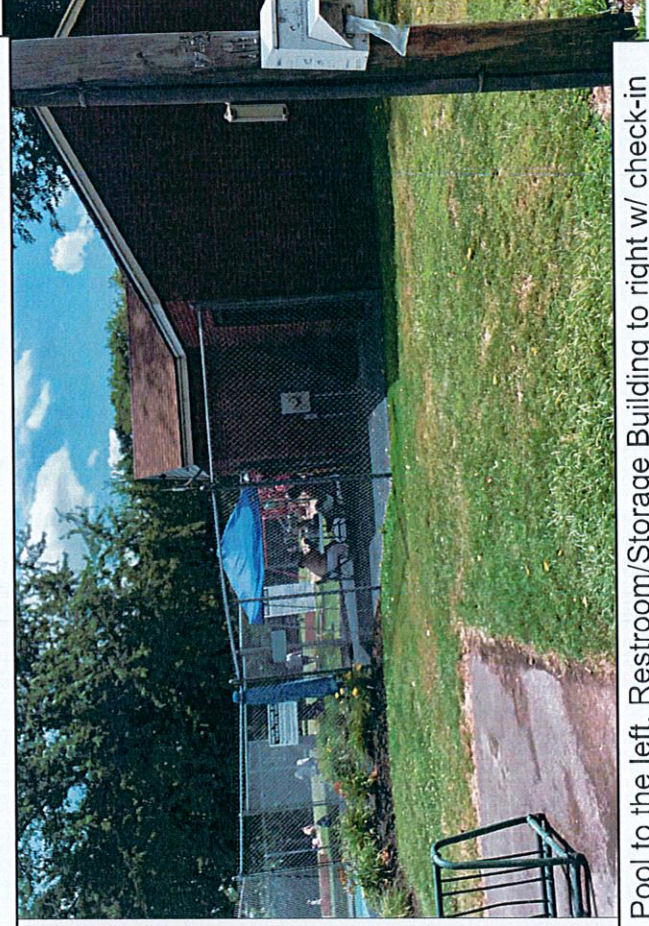

Pool to the left, Restroom/Storage Building to right w/ check-in under tent.

5 Year Plan
Kennedy Park Pool Area Renovation
Village of North Syracuse, NY

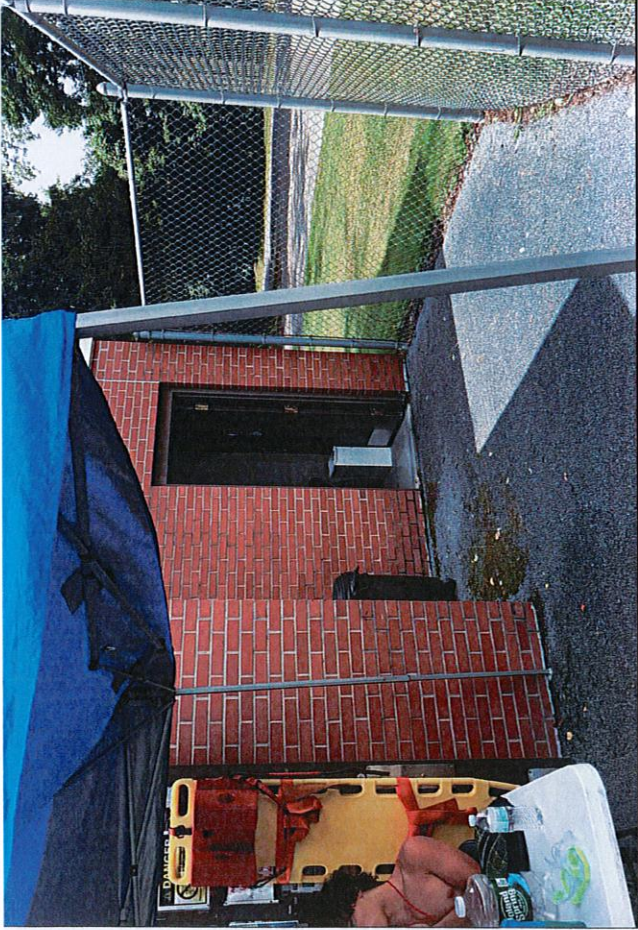

Restroom/Storage Building w/ check-in under tent.

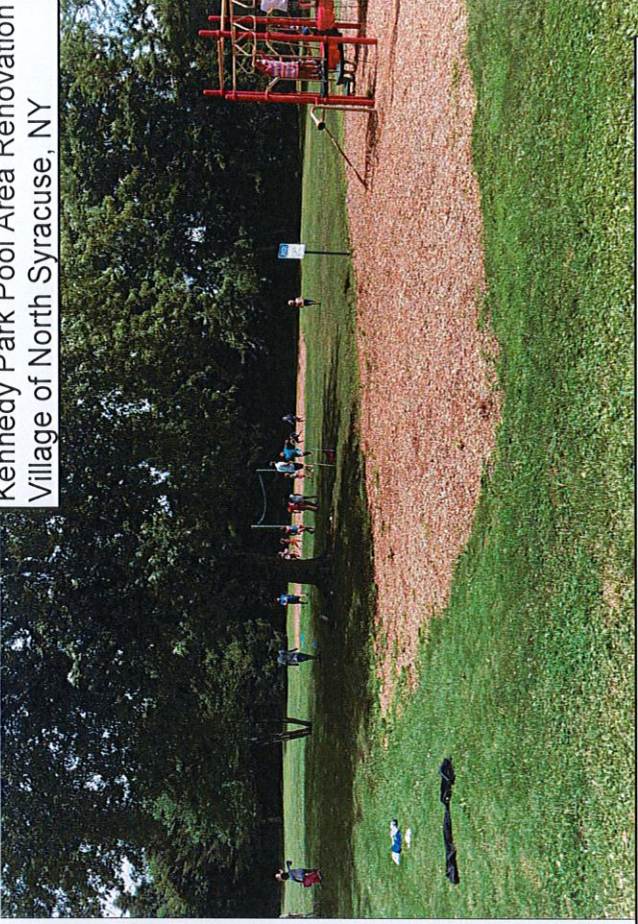

Park Amenities - Volleyball and Playground

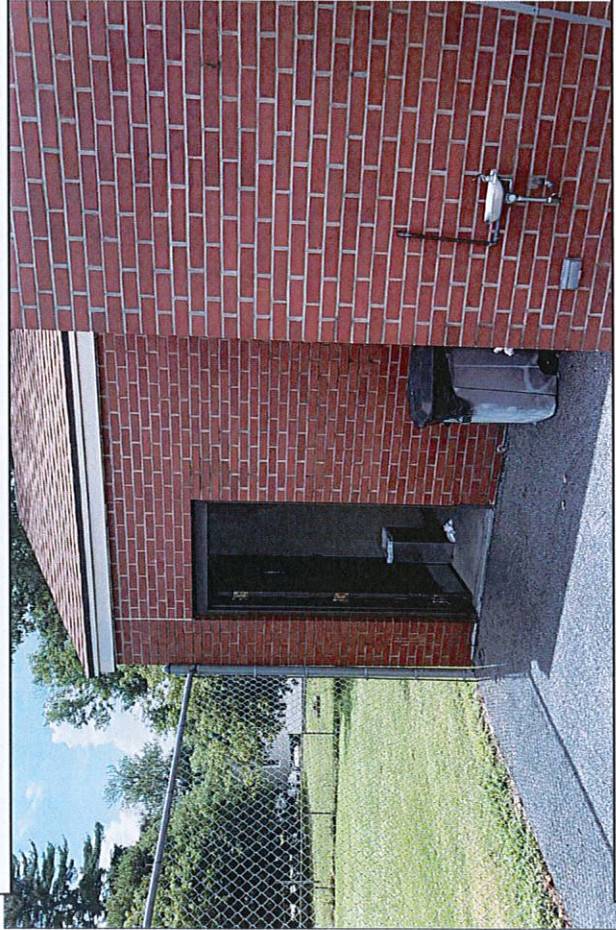

Restroom/Storage Building



Park Amenities - Volleyball and Playground

5 Year Plan
Kennedy Park Pool Area Renovation
Village of North Syracuse, NY



Shower Area.



Restroom Area & pass through for entrance to pool area.

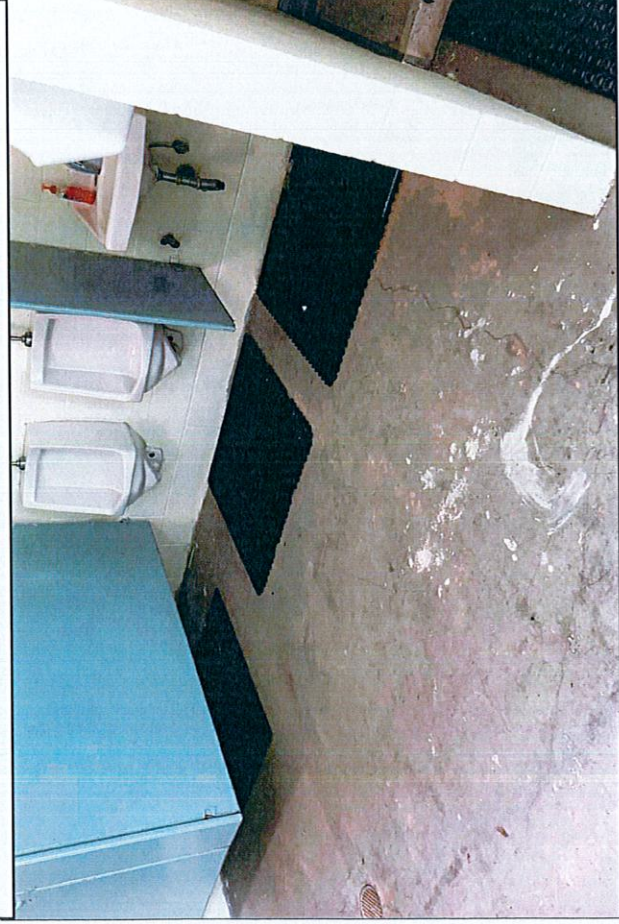

Restroom Area & pass through for entrance to pool area.

SHEET A-1	DATE 07/20/2022	SCALE AS NOTED
	NORTH SYRACUSE KENNEDY PARK POOL BATHROOM ACCESSIBILITY PROJECT GROVE STREET, NORTH SYRACUSE, N.Y.	
PROJECT NORTH 		
DRAWING REVISE FLOOR PLAN WITH NEW BUILDING & PARTIAL SITE		

Group 1 Design

3175 COLLEGE AVENUE
SYRACUSE, NY 13206
315.462.4400
315.462.8644

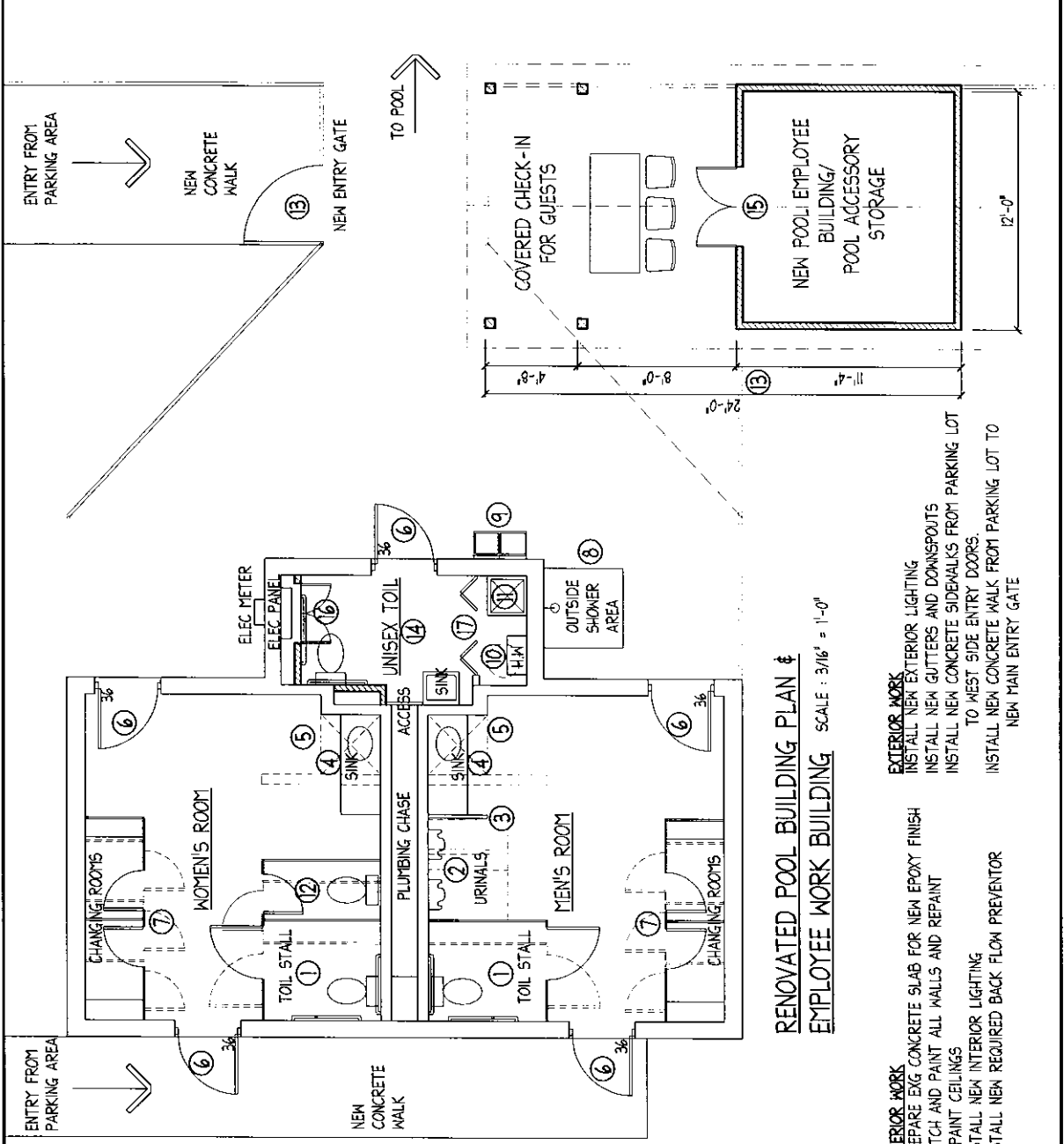

- PLAN NOTES AND INFORMATION**
- 1 REMOVE EXG TOIL STALL & INSTALL NEW HC COMPLIANT STALL
 - 2 REMOVE EXISTING URINALS & INSTALL 2 NEW URINALS WITH COMPLIANT USE AREA
 - 3 NEW PRIVACY SCREEN BETWEEN URINALS & COUNTER
 - 4 COUNTER, OPEN BELOW W/ SINK, PAPER TOWEL DISPENSER, SOAP DISPENSER
 - 5 REMOVE EXIST SHOWER & ALL PLUMBING
 - 6 REMOVE EXISTING HM DOORS & FRAMES & INSTALL NEW FRP DOORS & FRAMES & NEW COMPLIANT HARDWARE
 - 7 REMOVE EXIST 3 CHANGING RM PARTITIONS & DOORS & INSTALL 2 NEW LARGER CHANGING AREAS WITH SEAT/ BENCH AND INSURING DOORS
 - 8 INSTALL NEW SHOWER HEAD AT EXTER FACE OF WALL/ INSTALL DRAIN & REVISE GROUND SURFACE FOR DRAINAGE
 - 9 NEW HI-LOW BOTTLE FILLER FOUNTAIN AT EXTERIOR FACE OF WALL EXTERIOR FACE OF WALL/ INSTALL DRAIN AND REVISE GROUND SURFACE FOR DRAINAGE
 - 10 REMOVE EXISTING HW TANK & INSTALL NEW ON-DEMAND WALL MOUNTED HW HEATER
 - 11 REMOVE EXISTING MOP SINK AND INSTALL NEW FLOOR MOUNTED SINK
 - 12 REMOVE TOIL AND STALL AND INSTALL NEW STALL AND RELOCATE TOILET
 - 13 REVISE FENCING AS SHOWN AND ADD NEW ENTRY GATE, INSTALL NEW SIDEWALKS AND PLANTINGS
 - 14 INSTALL NEW HC TOILET AND GRAB BARS AND NEW SINK TO CREATE UNISEX TOIL RM
 - 15 NEW WOOD FRAME BUILDING, SLAB ON GRADE ON CHU FROST WALL, WOOD FRAMED WALLS AND TRUSSED ROOF
 - 16 CONSTRUCT NEW WALL WITH ACCESS PANEL FOR ELECTRIC PANEL
 - 17 CONSTRUCT NEW WALL ACCESS DOORS FOR MOP SINK AND WATER HEATER

RENOVATED POOL BUILDING PLAN & EMPLOYEE WORK BUILDING SCALE: 3/16" = 1'-0"

- INTERIOR WORK**
- PREPARE EXG CONCRETE SLAB FOR NEW EPOXY FINISH
 - PATCH AND PAINT ALL WALLS AND REPAIR
 - REPAIR CEILINGS
 - INSTALL NEW INTERIOR LIGHTING
 - INSTALL NEW REQUIRED BACK FLOW PREVENTOR
- EXTERIOR WORK**
- INSTALL NEW EXTERIOR LIGHTING
 - INSTALL NEW GUTTERS AND DOWNSPOUTS
 - INSTALL NEW CONCRETE SIDEWALKS FROM PARKING LOT TO WEST SIDE ENTRY DOORS.
 - INSTALL NEW CONCRETE WALK FROM PARKING LOT TO NEW MAIN ENTRY GATE

GROUP 1 DESIGN
 SHEILA WOOD, ARCHITECT
 817 S COLLINGWOOD AVENUE
 SYRACUSE, NY 13208
 GROUPFOUNDER@G1DESIGN.COM
 315.434.1844



PROJECT NORTH
 DRAWING
 EXISTING FLOOR PLAN & PARTIAL SITE
 NORTH SYRACUSE KENNEDY PARK
 POOL BATHROOM ACCESSIBILITY PROJECT
 GROVE STREET, NORTH SYRACUSE, N.Y.

SHEET
 EXISTING
 DATE 07/20/2022
 SCALE AS NOTED

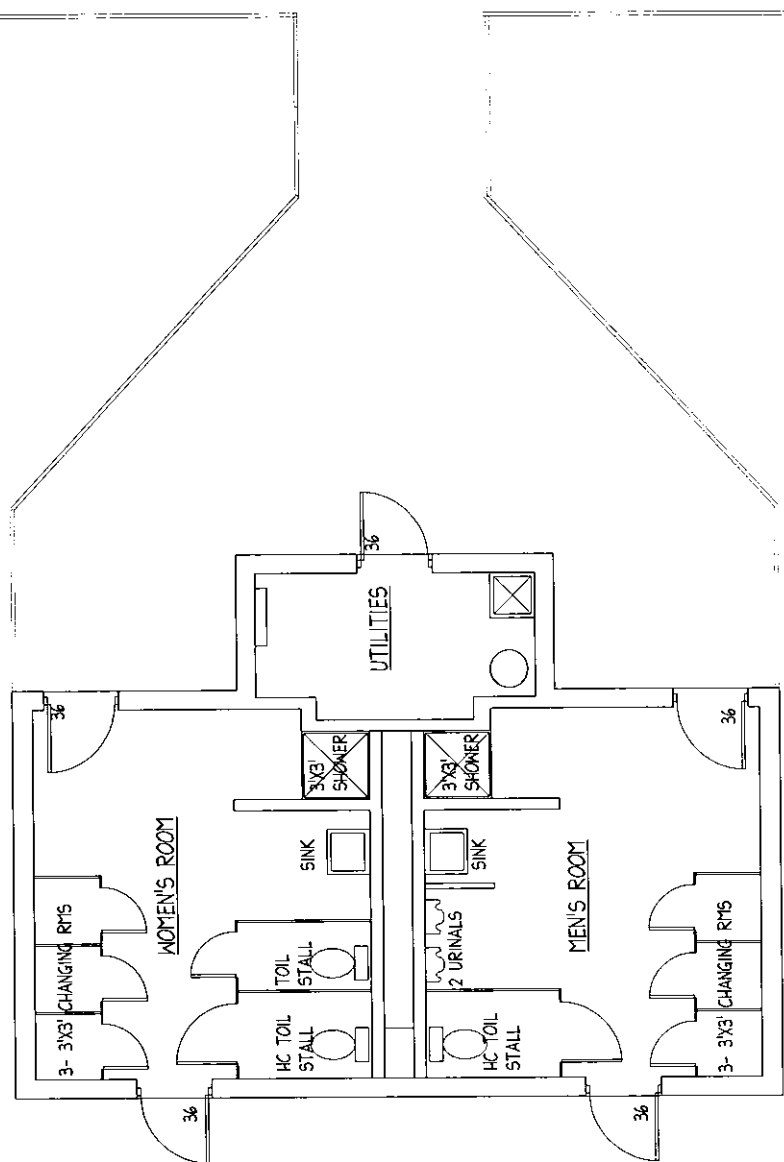

EXISTING POOL BUILDING PLAN

SCALE : 3/16" = 1'-0"

Kennedy Park Pool Area Renovation
 Village of North Syracuse
Preliminary Cost Estimate

ITEM	QTY	UNIT	UNIT COST	TOTAL
Toilet Facilities	1	LS	\$19,000.00	\$19,000.00
Changing Rooms	1	LS	\$32,000.00	\$32,000.00
ADA Upgrades	1	LS	\$8,000.00	\$8,000.00
Door & Frame Replacements	1	LS	\$5,000.00	\$5,000.00
Utility upgrades	1	LS	\$10,000.00	\$10,000.00
Addition	1	LS	\$100,000.00	\$100,000.00
			Subtotal	\$174,000.00
			Contingency (12%)	\$20,880.00
			Engineering, Legal, Fiscal Expenses (10%)	\$17,400.00
			TOTAL	\$212,280.00



LONERGAN PARK IMPROVEMENT PROJECT



Onondaga County CDBG
Village of North Syracuse
Lonergan Park
Cost Estimate

<u>ITEM</u>	<u>QTY</u>	<u>UNIT</u>	<u>UNIT COST</u>	<u>TOTAL</u>
Demolition & Removals	1	Lump Sum	\$5,000.00	\$5,000.00
Cover Gazebo Stage	1	Lump Sum	\$12,000.00	\$12,000.00
Electric Sign	1	EA	\$15,000.00	\$15,000.00
20 trees	20	EA	\$350.00	\$7,000.00
Mobilization/Demobilization	1	Lump Sum	\$10,000.00	\$10,000.00
			Subtotal	\$49,000.00
			Contingency (10%)	\$4,900.00
			Engineering, Legal, Fiscal Expenses (20%)	\$9,800.00
			TOTAL	\$63,700.00



CENTERVILLE PARK IMPROVEMENT PROJECT

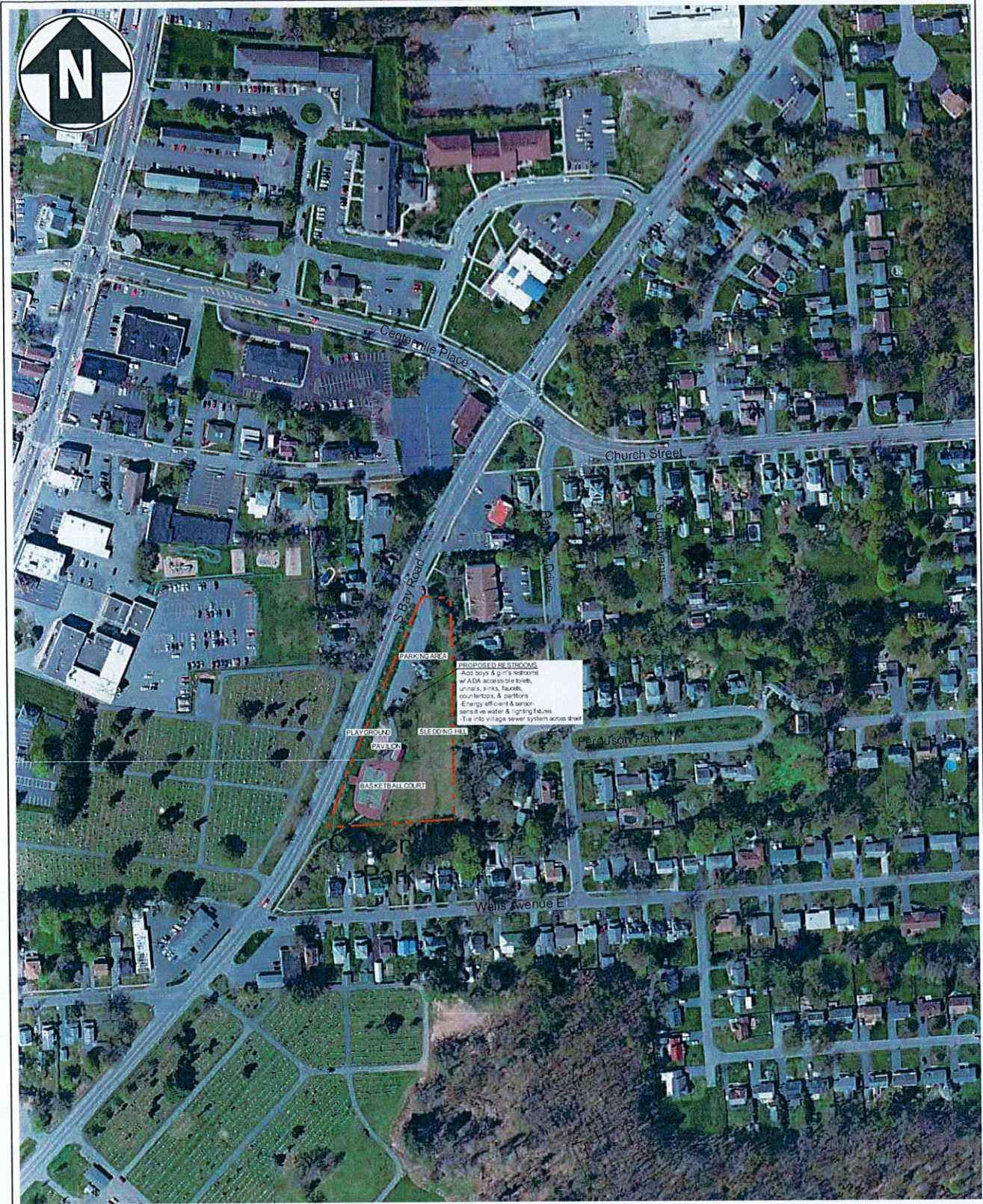

300 South State Street - Suite 600
 Syracuse, NY 13202
 315.471.3920 · www.chacompanies.com

Onondaga County Community Development Funding Request
 Village of North Syracuse
 Centerville Park ADA Compliant Restroom Development Project

Conceptual Layout

PROJECT NO.
 22016.1046

DATE: 03/15/19

Scale: 1" = 300'

**Onondaga County Community Development
Five-Year Plan
Village of North Syracuse
Phase 4 - Centerville Park Restroom Improvements
Cost Estimate**

<u>Item</u>	<u>Quantity</u>	<u>Unit</u>	<u>Unit Cost</u>	<u>Total</u>
Demolition & Removals	1	Lump Sum	\$20,000.00	\$20,000.00
Restroom Facility	1	Lump Sum	\$100,000.00	\$100,000.00
Sewer Pipe Station	1	Lump Sum	\$6,000.00	\$6,000.00
Sewer Pipe	86	LF	\$50.00	\$4,300.00
Toilets	2	EA	\$1,000.00	\$2,000.00
Urinals	1	EA	\$800.00	\$800.00
Toilet Tissue Dispenser	2	EA	\$160.00	\$320.00
Soap Dispenser (Automatic)	2	EA	\$150.00	\$300.00
Hand Dryer (Automatic)	2	EA	\$600.00	\$1,200.00
Sinks	2	EA	\$800.00	\$1,600.00
Faucets (Automatic)	2	EA	\$600.00	\$1,200.00
Mirrors	2	EA	\$600.00	\$1,200.00
Waste Receptacle	2	EA	\$600.00	\$1,200.00
Partitions	2	EA	\$6,200.00	\$12,400.00
Grab Bars	2	EA	\$400.00	\$800.00
Door Hooks	2	EA	\$20.00	\$40.00
Lighting	2	EA	\$300.00	\$600.00
Signage	2	EA	\$20.00	\$40.00
Wall Painting	1	LS	\$3,000.00	\$3,000.00
Slip Resistant Flooring	1	LS	\$9,000.00	\$9,000.00
Mobilization/Demobilization	1	Lump Sum	\$15,000.00	\$15,000.00
			Subtotal	\$181,000.00
			Contingency (10%)	\$18,100.00
			Engineering, Legal, Fiscal Expenses (20%)	\$36,200.00
			TOTAL	\$235,300.00
			OCCD Request	\$50,000.00
			Village 25% Match	\$12,500.00
			Village Contribution	\$185,300.00



SLEETH MILL PARK IMPROVEMENT PROJECT

TRAILS OPEN 8AM TO DUSK

THERE IS A CARRY-IN - CARRY-OUT TONNAGE POLICY

BIKE AND MOTORCYCLE VEHICLES PROHIBITED

FISHING, TAPPING, COLLECTING PROHIBITED

RETURN FROM AT THE MILL, WEST ON HAMILTON RD TO BAYTON CHURCH STREET TO HAMILTON CHURCH PARKING - 18' 24' 00"

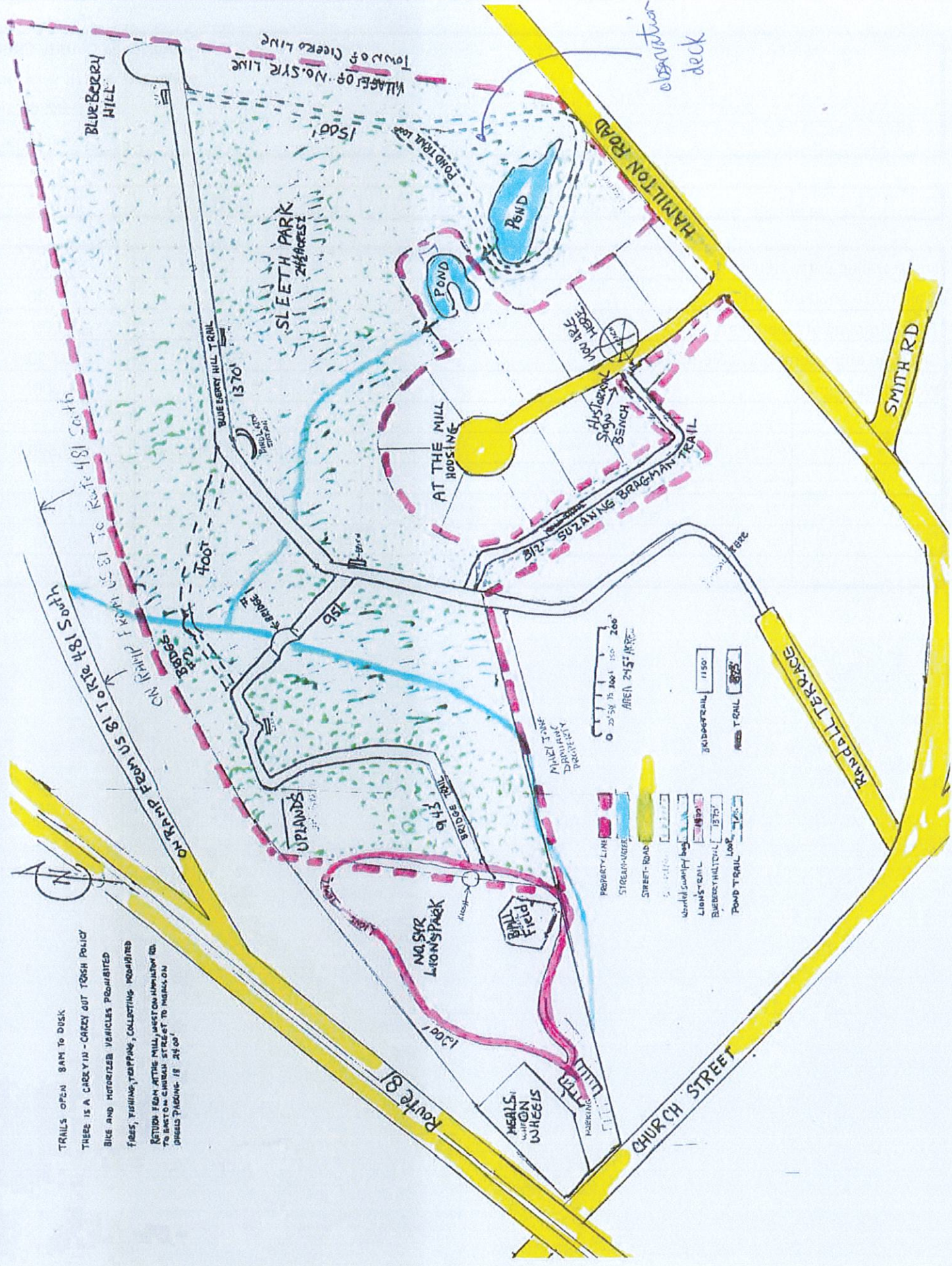

Onondaga County CDBG
 Village of North Syracuse
 Sleeth Mill Park
 Cost Estimate

	<u>ITEM</u>	<u>QTY</u>	<u>UNIT</u>	<u>UNIT COST</u>	<u>TOTAL</u>
	Freestanding Entry Signage	3	EA	\$2,500	\$7,500
	Trail Mulch at Sleeth Park	45	MSF	\$300	\$13,500
	Tree Trimming at Sleeth Park	1	AC	\$5,500	\$5,500
	Drainage Improvements at Sleeth Park	1	LS	\$18,000	\$18,000
	Wayfinding Signage	10	EA	\$400	\$4,000
				Subtotal	\$48,500
				Contingency (10%)	\$4,850
				Engineering & Legal (20%)	\$9,700
				Preliminary Cost Estimate	\$63,050



WALKABLE VILLAGE

Village of North Syracuse Onondaga County

NAME	DISTANCE MARKER	BENCH	POINTS OF INTEREST
1 Community Center	X	X	Recreation Hall for Residents functions
2 Memorial Park, South Side	X	X	Residents Memorial Trees
3 Centerville Park	X	X	Sledding Hill, Swigs Play Area
4 Lions Field Park	X	X	Softball Field
5 Sleeth Mills Bridge	X	X	Wooded Scenery, Small Babbling Stream
6 Sleeth Park	X	X	Wooded Walking Path
7 Blueberry Hill	X	X	Wooded to Open Scenery
8 Observation Deck	X	X	Bird or Wildlife Watching
9 Kennedy Park	X	X	Pool, Kids Play Area
10 Northlands Development	X	X	James Barry Historical Markers
11 Memorial Park, North Side	X	X	Residents Memorial Trees
12 Veleran's Memorial Park	X	X	5 Branch Military Service Memorial Bricks

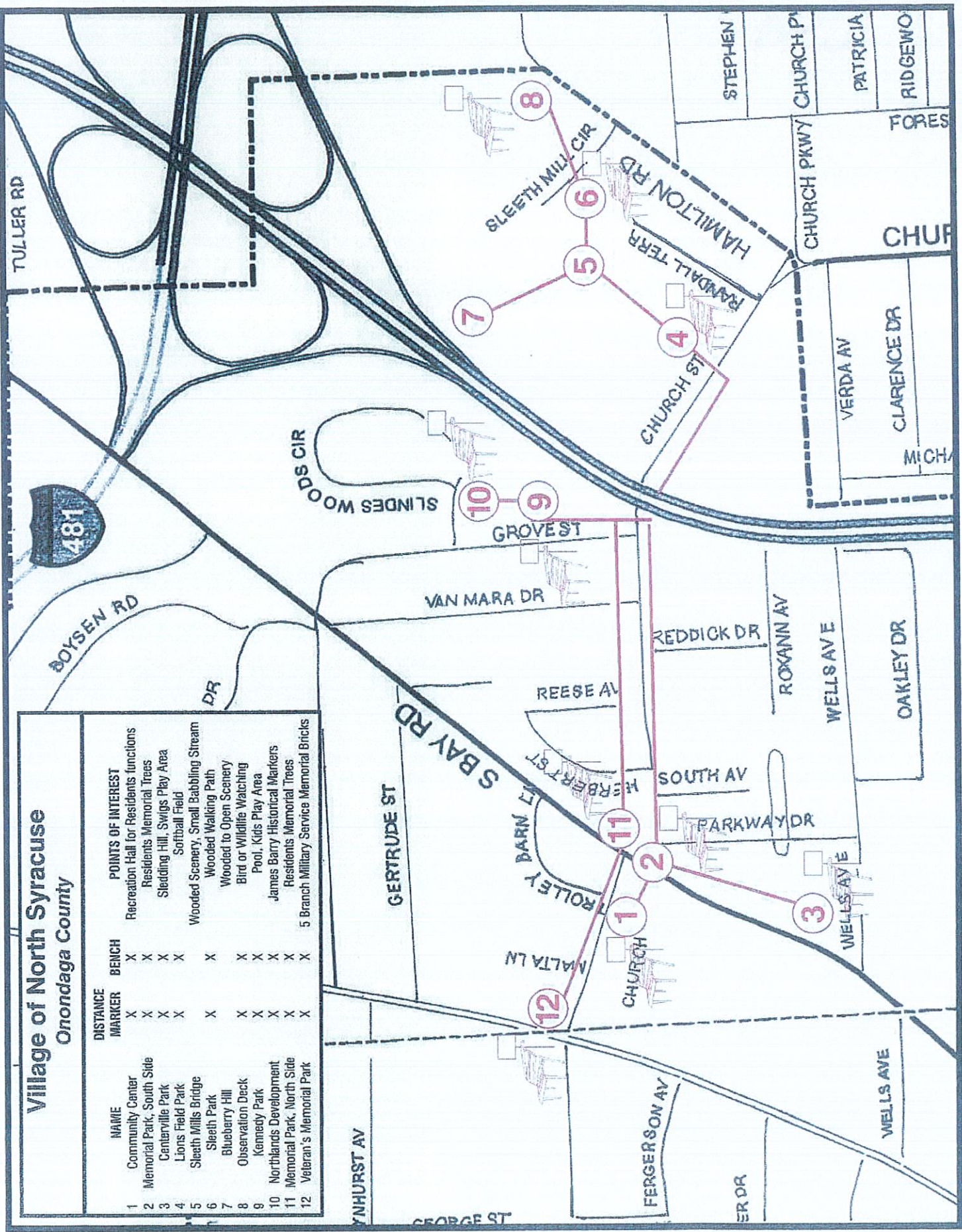

Onondaga County CDBG
Village of North Syracuse
Walkable Village
Cost Estimate

	<u>ITEM</u>	<u>QTY</u>	<u>UNIT</u>	<u>UNIT COST</u>	<u>TOTAL</u>
	Wayfinding Signage	5	EA	\$1,800	\$9,000
	Distance Markers	3	EA	\$550	\$1,650
	Building Mounted Overall Walkable Village Map Signage	2	EA	\$3,500	\$7,000
	Freestanding Overall Walkable Village Map Signage	4	EA	\$5,500	\$22,000
				Subtotal	\$39,650
				Contingency (10%)	\$3,965
				Engineering & Legal (20%)	\$7,930
				Preliminary Cost Estimate	\$51,545



VILLAGE-WIDE STREET DRAINAGE AND ROADWAY IMPROVEMENTS



CHA
300 South State Street - Suite 600
Syracuse, NY 13202
315.471.3920 · www.chacompanies.com

Onondaga County Community Development Funding Request
Village of North Syracuse
Drainage and Roadway Improvements

Conceptual Layout

PROJECT NO.
22016.1046
DATE: 03/15/19
Scale: 1"=400'

**Onondaga County Community Development
Five-Year Plan
Village of North Syracuse
Phase 5 - Village Street Drainage And Roadway Improvements
Cost Estimate**

Watson Road

Length of Road (ft): 2200

<u>Item</u>	<u>Quantity</u>	<u>Unit</u>	<u>Unit Cost</u>	<u>Total</u>
Asphalt Roadway Mill & Overlay (1-1/2" Top)	7500	SY	\$15.00	\$112,500.00
Green Infrastructure (4" perf. Underdrains)	4400	LF	\$10.00	\$44,000.00
Asphalt Driveway Restoration (underdrain)	420	SY	\$40.00	\$16,800.00
			Subtotal	\$173,300.00

Maxwell Avenue

Length of Road (ft): 2020

<u>Item</u>	<u>Quantity</u>	<u>Unit</u>	<u>Unit Cost</u>	<u>Total</u>
Asphalt Roadway Mill & Overlay (1-1/2" Top)	6750	SY	\$15.00	\$101,250.00
Green Infrastructure (4" perf. Underdrains)	4040	LF	\$10.00	\$40,400.00
Asphalt Driveway Restoration (underdrain)	520	SY	\$40.00	\$20,800.00
			Subtotal	\$162,450.00

Centerville Place

Length of Road (ft): 3000

<u>Item</u>	<u>Quantity</u>	<u>Unit</u>	<u>Unit Cost</u>	<u>Total</u>
HDPE Drainage Pipe	3000	LF	\$40.00	\$120,000.00
Pre-Cast Concrete Catch Basin	10	EACH	\$2,500.00	\$25,000.00
Asphalt Roadway Mill & Overlay (1-1/2" Top)	3500	SY	\$15.00	\$52,500.00
Supplemental Subbase Selected Areas w/ Binder Asphalt	1000	SY	\$30.00	\$30,000.00
Maintenance & Protection of Traffic	1	LS	\$5,000.00	\$5,000.00
			Subtotal	\$232,500.00

Subtotal	\$568,250.00
Contingency (10%)	\$56,825.00
Engineering, Legal, Fiscal Expenses (20%)	\$113,650.00
TOTAL	\$738,725.00
OCCD Request	\$50,000.00
Village 25% Match	\$12,500.00
Village Contribution	\$688,725.00

"There is an appointed time for everything. And there is a time for every event under heaven."

I am resigning the office of Mayor
of the Village of North Syracuse
effective end of day March 13, 2026

Gay Buttrick

RECEIVED
MAR 13 2026
VILLAGE OF N. SYRACUSE
CLERK/TREASURER

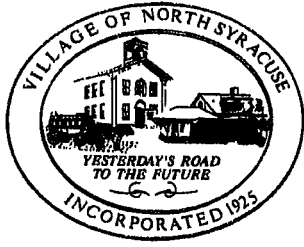

VILLAGE OF NORTH SYRACUSE

Regular Board Meeting

March 12, 2026 @ 5:30 PM

North Syracuse Community Center

700 South Bay Road, North Syracuse, NY

YouTube Livestreamed

The Village of North Syracuse Regular Board Meeting began at 5:30 P.M. with Mayor Butterfield asking everyone to join him in the Pledge of Allegiance.

Roll Call: Mayor Butterfield, Deputy Mayor D. Robinson, Trustee J. Bolton, Trustee F. Wilmer, Trustee L. St. Germain.

Personnel Present: Village Clerk-Treasurer N. Zarzecki, Deputy Fire Chief J. Asztalos, Police Chief C. Fieldson, DPW Foreman J. Wallace, Engineer A. Franco. A. Burkinshaw (frmr. Parks Director, to assist with A/V). Excused: Codes Director L. Nestell, Parks Director D. Radell, Village Attorney R. Germain.

RESOLUTION # 45-26

APPROVAL OF REG. BD. MTG. MINUTES- 2/26/2026

Trustee Bolton made a motion to approve the minutes from the February 26, 2026 Board Meeting. Motion was seconded by Trustee St. Germain. The motion was approved: Deputy Mayor Robinson, Trustee Wilmer, Trustee St. Germain, and Trustee Bolton all voting in favor of the same.

RESOLUTION # 46-26

GENERAL FUND ABSTRACT APPROVAL

Trustee Wilmer made a motion to approve General Fund Abstract #20 in the amount of \$104,073.94, covering voucher #1278 through #1350. Included in the abstract is a payment of \$13,518.96 for an annual payment for Taser Replacements (covered by CREST Grant from Senator Ryan). Motion was seconded by Trustee Bolton. The motion was approved: Deputy Mayor Robinson, Trustee Wilmer, Trustee St. Germain, and Trustee Bolton all voting in favor of the same.

NO BUDGET TRANSFERS

CITIZENS VOICE (This is the third of four meetings in a trial period to move the Citizens Voice ahead of business being discussed.)

Ken Ryan (211 Herman Dr) Stated the following:

- Hoping to get an answer regarding the Village following Code about abandoned pools.

Pat Fergerson (215 S. Main St) Stated the following:

- Many flower donations have been received. Donations go to Friends of the Village and that is a tax-deductible 509(a)(2). Donations for apx 2,100 of the 4,000 hanging baskets/gardening/pots have been received.

OLD BUSINESS

PRESENTATION BY HUEBER BREUER

Presentation By Hueber Breuer's Sean Foran updating the progress of the Proposed New Fire Department building project. Handout summarizing progress to date was provided. Site Plan ("Sheet A"); coming along well, no major issues at this time. Floor Plan ("Sheet B") – drawings are apx 60% developed. Building Elevations ("Sheet C"). Summary Sheet on top includes quick bullet items: design docs = apx 60% complete with final docs ready for permit review mid-April; project would be put to bid early May with Board approval; floor plan is apx 5,400 sq. ft (four apparatus spaces, support spaces,

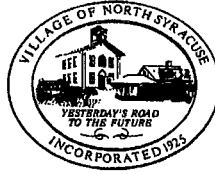

Village of North Syracuse
Regular Board Meeting
March 12, 2026 @ 5:30 PM

training mezzanine). Budget currently being reviewed; target still “all-in” for \$5 million with tax increase being \$68 per \$100,000 home value. Next steps are to complete bid documents and develop next steps for proceeding with the Village.

RESOLUTION # 47-26

DISCUSS/APPROVE ADJUSTED BOND RESOLUTION FOR FD TRUCK #1

Motion was made by Trustee Wilmer to accept an adjusted Bond Resolution to start the estoppel period on 3/12/2026 for the replacement of Truck #1 for the Fire Department. Bond Counsel provided the appropriate resolution to adopt and initiate the bonding process. Motion to approve a Bond Resolution to authorize a new fire-fighting vehicle not to exceed \$2,000,000 for seven or ten years (or 12 years). Motion was seconded by Trustee Bolton. The motion was approved: Deputy Mayor Robinson, Trustee Wilmer, Trustee St. Germain, and Trustee Bolton all voting in favor of the same.

NEW BUSINESS

DISCUSS/APPROVE INCREASE IN PAYMENT TO MEMBERS OF PLANNING AND ZONING BOARDS

Trustee Wilmer made a motion to discuss an increase in payment, effective 6/1/2026, to members of Planning and Zoning Boards to \$75.00 per meeting for members and \$100.00 per meeting for Chairperson. Motion was seconded by Deputy Mayor Robinson. Discussion included reasoning for the request to increase payment. The motion was opposed: Deputy Mayor Robinson, Trustee Wilmer, Trustee St. Germain, and Trustee Bolton all voting in favor of the same.

RESOLUTION # 48-26

DISCUSS/APPROVE APPT OF G. STEVENS TO DPW ASST. SUPT

Deputy Mayor Robinson made a motion to discuss/approve the appointment of Gilbert Stevens to DPW Assistant Superintendent provisionally, contingent on passing an exam when one becomes available. This would be effective 3/13/2026 and the salary will be set tentatively at \$60,000/year. The motion was seconded by Trustee Wilmer. The motion was approved: Deputy Mayor Robinson, Trustee Wilmer, Trustee St. Germain, and Trustee Bolton all voting in favor of the same.

RESOLUTION # 49-26

DISCUSS/APPROVE HIRING OF J. DAVIS & C. BRAGMAN AS F/T POLICE OFFICERS

Trustee Wimer made a motion to discuss/approve the hiring of Justin Davis and Cameron Bragman as full-time officers in the Police Department effective 3/16/2026 at the Recruit Pay salary per CBA. Both will be hired off current eligible Civil Service list and will begin their Police Academy Training at the Oswego County Police Academy on 3/30/2026. Motion was seconded by Trustee Bolton. The motion was approved: Deputy Mayor Robinson, Trustee Wilmer, Trustee St. Germain, and Trustee Bolton all voting in favor of the same.

RESOLUTION # 50-26

DISCUSS/APPROVE ATTENDANCE AT NYS ASSOC. OF CHIEFS OF POLICE CONFERENCE

Trustee Wimer made a motion to discuss/approve Police Chief Fieldson’s attendance at the NYS Association of Chiefs of Police Conference in Lake Placid May 18th-21st. This item is budgeted and contractual. Motion was seconded by Trustee St. Germain. The motion was approved: Deputy Mayor Robinson, Trustee Wilmer, Trustee St. Germain, and Trustee Bolton all voting in favor of the same.



Village of North Syracuse
Regular Board Meeting
March 12, 2026 @ 5:30 PM

RESOLUTION # 51-26

DISCUSS/APPROVE SECTION 211 WAIVERS K. ISYK & R. MARSHALL

Trustee Wimer made a motion to discuss/approve signing Section 211 Waivers for Officers Ken Isyk and Robert Marshall, effective 3/13/2026. The waivers are designed to waive retiree earning limits and will allow the officers to assist with current and projected staffing shortages. Motion was seconded by Trustee Bolton. The motion was approved: Deputy Mayor Robinson, Trustee Wilmer, Trustee St. Germain, and Trustee Bolton all voting in favor of the same.

RESOLUTION # 52-26

DISCUSS/APPROVE APPT OF M. YORKEY AS VOL FIREFIGHTER

Trustee Wimer made a motion to discuss/approve the appointment of Mark Yorkey as a new Volunteer Firefighter for the North Syracuse Fire Department. Motion was seconded by Trustee St. Germain. The motion was approved: Deputy Mayor Robinson, Trustee Wilmer, Trustee St. Germain, and Trustee Bolton all voting in favor of the same.

RESOLUTION # 53-26

SET DATE FOR PUBLIC HEARING RE: 5-YEAR COMM. DEV. PLAN

Deputy Mayor Robinson made a motion to set the date for a Public Hearing for community input regarding the application and update to our 5-year Community Development Plan. The application for the 5-Year Community Development Plan is due by 4/10/26; Public Hearing will be held on 3/26/26 ahead of the scheduled Village Board Meeting. Motion was seconded by Trustee Wilmer. The motion was approved: Deputy Mayor Robinson, Trustee Wilmer, Trustee St. Germain, and Trustee Bolton all voting in favor of the same.

RESOLUTION # 54-26

**SET DATE FOR PUBLIC HEARING RE: CODE CHANGE
UNDER PD ZONE FOR NSVFD BLDG**

Trustee Bolton made a motion to set the date for a Public Hearing regarding a potential change to code under the PD Zone for the proposed Fire Department building. A Public Hearing will be held on 4/9/26 ahead of the scheduled Village Board Meeting. Motion was seconded by Trustee Wilmer. The motion was approved: Deputy Mayor Robinson, Trustee Wilmer, Trustee St. Germain, and Trustee Bolton all voting in favor of the same.

RESOLUTION # 55-26

SET DATE FOR PUBLIC HEARING RE: LOCAL LAW #1

Trustee Wilmer made a motion to set the date for a Public Hearing regarding Local Law #1 passing of the tax levy over the 2% tax limit. A Public Hearing will be held on 3/26/26 ahead of the scheduled Village Board Meeting. Motion was seconded by Trustee Bolton. The motion was approved: Deputy Mayor Robinson, Trustee Wilmer, Trustee St. Germain, and Trustee Bolton all voting in favor of the same.

RESOLUTION # 56-26

SET DATE FOR PUBLIC HEARING RE: FY 2026-2027 TENTATIVE BUDGET

Deputy Mayor Robinson made a motion to set the date for a Public Hearing regarding the tentative budget for FY 2026/2027. The deadline to hold a public hearing is April 15th. A Public Hearing will be held on 4/9/26 ahead of the scheduled Village Board Meeting. Motion was seconded by Trustee Bolton. The motion was approved: Deputy Mayor Robinson, Trustee Wilmer, Trustee St. Germain, and Trustee Bolton all voting in favor of the same.



Village of North Syracuse
Regular Board Meeting
March 12, 2026 @ 5:30 PM

DEPARTMENT HEAD REPORTS

CODES: TRUSTEE ST. GERMAIN on behalf of L. NESTELL Stated the following:

- Dollar General renovations will be completed and ready to open on 4/20.
- In past two weeks, there have been five violations written for property maintenance and doing work without a permit.
- Three cases are in court.
- "Permit season" is warming up; more permit requests coming in.
- Fire Inspections are studied each week.
- Most of the apartment complexes are completed for the registry; the verbiage for the apartment registration is complete and will be delivered to the Board next month.
- Software migration is complete but needs to be cleaned up. Meeting on 3/13 with iWorQ on how to move forward. Eric also offered to assist.
- Regarding the abandoned pool inquiry, that case is in court. The court advised that it is her Constitutional right to complete the work, she does not want to fill it in.

DPW: ASST. SUPT. J. WALLACE Stated the following:

- Currently doing coal patching.
- Currently doing building maintenance.
- Currently trying to do vehicle maintenance; having some issues with a couple of pieces of equipment for picking up brush and heavy trash.
 - Loader is currently down (10-15 days); A ram on the bucket went.
 - Once back in service, brush truck will be going down (hydraulic issues).

FIRE DEPARTMENT: DEPUTY CHIEF J. ASZTALOS Stated the following:

- Thank you to the Board for replacement of Truck 1.
- NSFD responded on 3/11 at apx 11:30pm to an incident at Woodland Garden Apartments (460 S. Main St)
 - Currently under investigation (NYS Police, Office of Emergency Management Fire Investigators)
 - Multiple building had intentional fires set; none spread beyond area of origin due to quick work by NSFD and mutual aid partners.
 - Encourage residents to secure property and be vigilant.
- Date that Model One of the budget will be sent? (Per Mayor Butterfield – will be sent 3/13/26)
- Thanked Deputy Mayor Robinson for coming to the firehouse over the weekend and learning about FD operations, projects, etc.

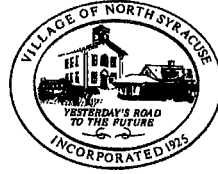

Village of North Syracuse
Regular Board Meeting
March 12, 2026 @ 5:30 PM

- Statement prepared as member of the Fireman's Association, not as Fire Chief, with permission from Fireman's Association President and Chairmand of the Board:
 - To Mayor Gary Butterfield and the Village Board of Trustees from the North Syracuse Volunteer Firefighters Association, dated today, regarding direct fiscal impact of the North Syracuse Volunteer Firemen's Association financial contributions 2020 to 2025.

The North Syracuse Volunteer Firefighters Association provides a substantial documented offset to the village's fire protection budget. The association has absorbed hundreds of thousands of dollars in departmental costs since January 1st, 2020. This memorandum, which I'll provide a copy to everybody, outlines some of the equipment, infrastructure, and operational items funded entirely or in part by the association and their approximate rounded down cost. Please know that this is no way a comprehensive list, but we wanted to take this opportunity to educate both the board and the public on the advantages that the association provides. For example, this doesn't include the facilitation of purchasing varied vehicles, rather a summary of easy to convey items. Major capital improvement and equipment purchases. These following one-time high value items were purchased or funded by the association, directly sparing the village's capital improvement expenses.

- In 2020, the Firemen's Association installed turnout gear lockers in compliance with new NFPA standards. The installation was \$4,500.
- Coincidentally, the association also purchased those gear lockers. They were just previous to 2020.
- In 2020, on Truck 1, Engine 4, Engine 6, and Rescue 7, the association purchased and had installed vehicle headsets, improving vehicle and firefighter safety to the tune of \$30,000.
- The association pays for all the information technology for the fire department, including a server replacement in 2020, to the tune of \$5,600.
- They renovated our training room in 2020 to the tune of \$9,400.
- They renovated the bump room and washer and dryers at Station 1, \$4,100 in 2021.
- They funded the radio room renovation in 2021 to \$7,600.
- And then in 2026, you'll notice that there's a significant gap there.
- The Fireman's Association is endeavoring to renovate the Station One kitchen to the tune of \$65,000.
- On top of those one-time capital expenses, there are specific line items that the association covers annually.
- If the association were to cease these payments, the fire department would be forced to increase the operating budget by approximately \$75,000 per year.
- Computer and information technology over five years, the association has paid \$75,000.
- Uniforms.
- \$15,500, training \$21,000, public education \$75,000, health and wellness \$70,000, and the maintenance of our antique apparatus \$5,000 for a grand total of \$261,500 over five years.

Beyond the contributions listed above, the association funding of soft costs, insurance, morale, and benefits protects the village from the single greatest potential expense, the transition to a paid fire department. By partnering with the North Syracuse Fire Department through association funds, the village avoids an estimated \$2.5 to \$4 million in annual personnel costs that a career department would require. The NSVA is a primary partner with the Village of North Syracuse Fire Department. These contributions represent over \$400,000 in the last five years and beyond since the incorporation of the association. They represent a significant taxpayer dividend, allowing the village to maintain a premier level of protection while keeping municipal debt and taxes significantly lower.

So we respectfully submit this for education purposes to everybody, so you understand a little bit more about the benefits of the Fireman's Association.

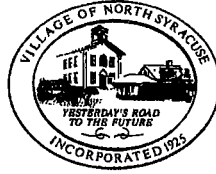

Village of North Syracuse
Regular Board Meeting
March 12, 2026 @ 5:30 PM

ENGINEERING: A. FRANCO Stated the following:

- No Report

PARKS & RECREATION (Excused)

POLICE DEPARTMENT: CHIEF C. FIELDSON Stated the following:

- Statistics for the month of February:
 - 524 total events
 - 226 property checks
 - 8 domestic incidents
 - 15 motor vehicle crashes investigated
 - 57 traffic stops
 - 40 traffic tickets
 - 9 criminal arrests
 - 3 DWIs
 - 1 larceny
- Winter parking ban in effect until April 15th: 1am – 8am

CLERK-TREASURER: N. ZARZECKI Stated the following:

- Model One of the budget is completed; work sessions need to be scheduled with Dept Heads before Public Hearings and before final tax levies decided on.
- Flower donations have been steadily coming in.

ATTORNEY REPORT (Excused)

DEPUTY MAYOR/TRUSTEES REPORTS

TRUSTEE ST. GERMAIN Stated the following:

- Apologized for recent absences; father has had heart issues and hopefully he will continue to do better.
- All Village departments are extremely important, and the FP and PD budgets are the biggest budgets because they are the most requested services.

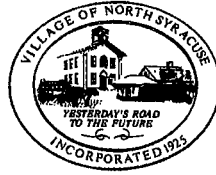

Village of North Syracuse
Regular Board Meeting
March 12, 2026 @ 5:30 PM

TRUSTEE WILMER Stated the following:

- Would like to make a motion to have an audit performed for Village finances for 2023-2024 (Mayor requested to address this during his report).

TRUSTEE BOLTON Stated the following:

- Attended a press conference in E. Syracuse last week where NYS Fire Chiefs Association presented information about recruiting and retaining volunteer firefighters.
- Attended Tree City luncheon in E. Syracuse on 3/12/26, representing the Village.
 - Village has been a Tree City for 37 years; one of longest of all NY municipalities.

DEPUTY MAYOR ROBINSON Stated the following:

- Acknowledged appreciation to Fire Chief for recent meeting; educational and enlightening.

MAYOR'S REPORT

Mayor Butterfield Stated the following:

- Annual Comptroller's report measuring fiscal and environmental stress of the village reported Village of North Syracuse at a three-year aggregated financial stress score of 3.3 (zero being the best, 100 being the worst).
- Former Clerk-Treasurer's medical issues prevented the AFR being submitted on time. They were submitted, very accurately, however.
- An audit is conducted on the village every year by an independent accounting firm. This costs \$18,000 and is in the budget.
 - Information can be obtained from the Comptroller's Office; another audit is not necessary.
- **RESOLUTION # 57-26** **DISCUSS/APPROVE AN IMMEDIATE FINANCIAL AUDIT FOR FY 23/24**
- Trustee Wilmer made a motion to discuss/approve having an audit performed for Village finances for FY 2023-2024. Motion was seconded by Trustee Bolton. Discussion was held. This motion was made due to the change in Clerk-Treasurer and want for a "clean slate" for new Clerk-Treasurer. Mayor reiterated that an annual audit/review is already completed for the Village, the information can be obtained from Clerk-Treasurer, and the cost for another one would likely be very high. The motion was approved: Trustee Wilmer, Trustee St. Germain, and Trustee Bolton all voting in favor of the same. Deputy Mayor Robinson opposed.
- **RESOLUTION # 58-26** **DISCUSS/APPROVE OBTAINING RFP FOR FINANCIAL AUDIT FOR FY 23/24**
- Trustee Wilmer made a motion to discuss/approve obtaining an RFP (Request for Proposal) from the Fund Balance for an immediate audit to be performed for Village finances for FY 2023-2024. Motion was



Village of North Syracuse
Regular Board Meeting
March 12, 2026 @ 5:30 PM

seconded by Trustee Bolton The motion was approved: Trustee Wilmer, Trustee St. Germain, and Trustee Bolton all voting in favor of the same. Deputy Mayor Robinson opposed.

- Police Officers were observed potentially raiding Skunk City Smoke Shop

DISCUSS/APPROVE DPW EMERGENCY GENERATOR REPLACEMENT

Deputy Mayor Robinson made a motion to discuss/approve and emergency purchase for a DPW generator that quit; three people have looked at it and determined it is not able to be fixed. Since the generator is a necessity at the DPW, this is considered an emergency repair. Three prices for new generators were obtained, with the low price being \$11,700 (includes sub-panel). Motion was seconded by Trustee St. Germain. Trustee Bolton initiated discussion; Board has not received any information on this emergency purchase (size, capabilities, warranties, etc) and since DPW, Mayor, and Trustee Liaison Robinson have been aware of issues for a couple of weeks, this is not an emergency. Motion was denied: Deputy Mayor Robinson and Mayor Butterfield voting in favor of, and Trustee Wilmer, Trustee St. Germain, and Trustee Bolton all voting against.

Trustee Wilmer made the motion to adjourn to Executive Session at 6:45pm to discuss a personnel issue. The motion was seconded by Trustee Bolton. The motion was approved; Deputy Mayor Robinson, Trustee St. Germain, Trustee Wilmer, and Trustee Bolton all voting in favor of the same.

Trustee Wilmer made the motion to end Executive Session and move to Regular Board Meeting at 7:54 PM. The motion was seconded by Trustee St. Germain. The motion was approved: Deputy Mayor Robinson, Trustee St. Germain, Trustee Wilmer, and Trustee Bolton all voting in favor of the same. In attendance for Executive Session was Mayor Butterfield, Trustee St. Germain, Trustee Wilmer, Deputy Mayor Robinson, and Trustee Bolton.

Deputy Mayor Robinson made the motion to adjourn at 7:55 P.M. The motion was seconded by Trustee Bolton. The motion was approved: Deputy Mayor Robinson, Trustee St. Germain, Trustee Wilmer, and Trustee Bolton all voting in favor of the same.

Respectfully Submitted,

Nick Zarzecki
Village Clerk-Treasurer

BUDGET TRANSFERS

BOARD APPROVAL NOT NECESSARY
USE BETWEEN THE SAME OBJECT ACCOUNTS

cc: Dianne

cc: w/requisition

From: (Account #): _____

To: (Account #): _____

Amount: _____

Reason: _____

BUDGET ADJUSTMENTS

BOARD APPROVAL NECESSARY
USE BETWEEN THE DIFFERENT OBJECT ACCOUNTS

From: (Account #): 7020.13 (RECREATION SUPERVISOR SALARY)

To: (Account #): 7020.21 RECREATION SOFTWARE

Amount: \$480

Reason: COVER Cost of Annual license fee for HERITAGE
Park Bathroom Locks

From Account #	To Account #
()	(7020.21)

Present Account Balance: \$ 13,989.94 \$ 0
Change: \$ 480 \$ 480.00

New Account Balance: \$ 13,509.94 \$ 480.00

Signature of Department Head
(To approve the transfer)

Don Radtke

Date:

3/20/26

NOTICE OF BOND RESOLUTION

The resolution, a summary of which is published herewith, was adopted on March 12, 2026. The resolution was subject to permissive referendum and the period of time has elapsed for the submission and filing of a petition for a permissive referendum. A valid petition has not been submitted and filed. The validity of the obligations authorized by such resolution may be hereafter contested only if such obligations were authorized for an object or purpose for which the Village of North Syracuse, Onondaga County, New York is not authorized to expend money or if the provisions of law which should have been complied with as of the date of publication of this notice were not substantially complied with, and an action, suit or proceeding contesting such validity is commenced within twenty days after the date of publication of this notice, or such obligations were authorized in violation of the provisions of the constitution.

Nick Zarzecki, Village Clerk

SUMMARY OF BOND RESOLUTION

A Bond Resolution adopted by the Board of Trustees of the Village of North Syracuse, Onondaga County, New York (the "Village") on March 12, 2026 authorizes the acquisition of a fire fighting vehicle (the "Project") at a maximum estimated cost of \$2,000,000. To pay the cost of the Project, there are authorized to be issued \$2,000,000 serial bonds of the Village. The plan for the financing thereof is the issuance of up to \$2,000,000, or such amount less than \$2,000,000 as may be necessary, of serial bonds or any bond anticipation notes, including renewals of such notes, in anticipation of the issuance and sale of the bonds of said Village, authorized to be issued pursuant to the Local Finance Law and the levy of a tax to pay principal and interest on said obligations, and the application, if and when available, of any state or federal grants-in-aid. The bonds and notes authorized may be issued to the United States Department of Agriculture, Office of Rural Development, or any of its related offices or agencies, the New York State Environmental Facilities Corporation under any of its revolving fund programs or any purchaser in accordance with the provisions of the Local Finance Law. The power to authorize the issuance of and to sell bond anticipation notes in anticipation of the issuance and sale of the serial bonds herein authorized, including renewals of such notes, is delegated to the Village Treasurer. The period of probable usefulness of the Project is twenty (20) years. The full faith and credit of the Village is irrevocably pledged for the payment of the principal of and interest on such bonds as the same respectively become due and payable. An annual appropriation shall be made in each year sufficient to pay the principal of and interest on such bonds becoming due and payable in such year. There shall annually be levied on all the taxable real property of said Village a tax sufficient to pay the principal of and interest on such bonds as the same become due and payable. The Village determined that the Project constitutes a "Type II Action" under the New York State Environmental Quality Review Act. Such resolution shall be kept available for public inspection in the Village Offices during regular business hours for twenty days following this publication.

CERTIFICATION OF POSTING

STATE OF NEW YORK)
) ss.:
COUNTY OF ONONDAGA)

I, the undersigned Clerk of the Village of North Syracuse in the County of Onondaga, New York,

DO HEREBY CERTIFY:

That on the 16TH day of MARCH, 2026, I caused to be posted a Notice of Adoption of a bond resolution dated March 12, 2026 relating to the acquisition of a new fire fighting vehicle, at the following six (6) conspicuous public places in said Village:

- VILLAGE OF NORTH SYRACUSE OFFICES - 600 S. BAY RD.
- NORTH SYRACUSE COMMUNITY CENTER - 700 S. BAY RD.
- NORTH SYRACUSE PUBLIC LIBRARY - 100 TROLLEY BARN LN.
- SOLWAY BANK - 628 S. MAIN ST.
- M+T BANK - 507 S. MAIN ST.
- NORTH SYRACUSE MASONIC MEMORIAL - 648 CENTERVILLE PL.

A true, correct and complete copy of such Notice of Adoption, in the exact form in which the same was actually posted, is attached hereto and made a part hereof.

IN WITNESS WHEREOF, I have hereunto set my hand and affixed the seal of said Village this 18TH day of MARCH, 2026.

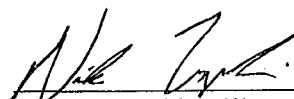

Nick Zarzecki, Village Clerk

(VILLAGE SEAL)

VILLAGE OF NORTH SYRACUSE
ONONDAGA COUNTY, NEW YORK
SUMMARY - FIRE APPARATUS



Fire Station Addition	Estimated Project Cost	Bond Term	Estimated Interest Rate	Estimated Yearly Average Debt Service	Amount Applicable to Cicero (34.0251%)	Amount Applicable to Clay (64.9749%)	Impact per \$1,000 AV for Cicero	Impact per \$1,000 AV for Clay
A	\$1,938,211	7 Years	3.65%	\$318,827	\$108,481.09	\$210,345.80	\$0.9716	\$24.9084
B	\$1,938,211	10 Years	3.75%	\$236,058	\$80,318.96	\$155,739.18	\$0.7194	\$18.4421
C	\$1,938,211	12 Years	3.90%	\$205,419	\$69,894.06	\$135,525.21	\$0.6260	\$16.0484

Notes:

- Percentage applicable based on 2025/26 values.
- Cicero AV - \$111,651,419 and Clay AV - \$8,444,766.

Prepared by:

FA Fiscal Advisors & Marketing, Inc.



3/10/2026

VILLAGE OF NORTH SYRACUSE

ONONDAGA COUNTY, NEW YORK

ESTIMATED DEBT SERVICE SCHEDULE - FIRE APPARATUS



Assumptions:

- Maintain level debt for this project.
- PPU likely 20/25 years, bond term 7 years. \$2M approved, actual cost lower.

(1)	(2)	(3)	(4)	(5)
Year Ending 31-May	Balance Outstanding	Principal Payment	Estimated Interest 3.65%	Total Debt Service
1	1,938,211	248,211	70,745	318,956
2	1,690,000	255,000	61,685	316,685
3	1,435,000	265,000	52,378	317,378
4	1,170,000	275,000	42,705	317,705
5	895,000	290,000	32,668	322,668
6	605,000	295,000	22,083	317,083
7	310,000	310,000	11,315	321,315
TOTALS		1,938,211	293,577	2,231,788

Average Life	4.15 Yrs	Average	\$ 318,827
--------------	----------	---------	------------

Prepared by:
Fiscal Advisors & Marketing, Inc.
3/10/2026



VILLAGE OF NORTH SYRACUSE

ONONDAGA COUNTY, NEW YORK

ESTIMATED DEBT SERVICE SCHEDULE - FIRE APPARATUS



Assumptions:

- Maintain level debt for this project.
- PPU likely 20/25 years, bond term 10 years. \$2M approved, actual cost lower.

(1)	(2)	(3)	(4)	(5)
Year Ending 31-May	Balance Outstanding	Principal Payment	Estimated Interest 3.75%	Total Debt Service
1	1,938,211	163,211	72,683	235,894
2	1,775,000	170,000	66,563	236,563
3	1,605,000	175,000	60,188	235,188
4	1,430,000	180,000	53,625	233,625
5	1,250,000	190,000	46,875	236,875
6	1,060,000	195,000	39,750	234,750
7	865,000	205,000	32,438	237,438
8	660,000	210,000	24,750	234,750
9	450,000	220,000	16,875	236,875
10	230,000	230,000	8,625	238,625
TOTALS		1,938,211	422,370	2,360,581

Average Life	5.81 Yrs	Average \$	236,058
--------------	----------	------------	---------

Prepared by:
Fiscal Advisors & Marketing, Inc.
3/10/2026



VILLAGE OF NORTH SYRACUSE

ONONDAGA COUNTY, NEW YORK

ESTIMATED DEBT SERVICE SCHEDULE - FIRE APPARATUS



Assumptions:

- Maintain level debt for this project.
- PPU likely 20/25 years, bond term 12 years. Approved \$2M.

(1)	(2)	(3)	(4)	(5)
Year Ending 31-May	Balance Outstanding	Principal Payment	Estimated Interest 3.90%	Total Debt Service
1	1,938,211	128,211	75,590	203,801
2	1,810,000	135,000	70,590	205,590
3	1,675,000	140,000	65,325	205,325
4	1,535,000	145,000	59,865	204,865
5	1,390,000	150,000	54,210	204,210
6	1,240,000	155,000	48,360	203,360
7	1,085,000	165,000	42,315	207,315
8	920,000	170,000	35,880	205,880
9	750,000	175,000	29,250	204,250
10	575,000	185,000	22,425	207,425
11	390,000	190,000	15,210	205,210
12	200,000	200,000	7,800	207,800
TOTALS		1,938,211	526,820	2,465,031
Average Life		6.97 Yrs	Average	\$ 205,419

Prepared by:
Fiscal Advisors & Marketing, Inc.
3/10/2026





Supervisor
Michael Aregano

Town Council
Michael Becallo
Jonathan Karp
Michael Mirizio
Ashley Hogan

Town of Cicero
8236 Brewerton Road, Cicero NY 13039
Phone: 315-752-1180 Fax: 315-699-0039

www.ciceronewyork.net

Town Clerk
Tracy Cosilmon

Highway Superintendent
Christopher Woznica

Receiver of Taxes
Kari Davis

October 23, 2025

Mayor Gary Butterfield
Village of North Syracuse
600 South Bay Road
North Syracuse, NY 13212

Dear Mayor Butterfield,

I have enclosed two copies of the 2026 Fire Contracts with the North Syracuse Fire Department, approved by the Cicero Town Board on October 22, 2025, at the Town Board Meeting.

Please execute both copies of the contract, retain one for your files, and return the following to me:

One original of the executed contract
The signed voucher
A current certificate of required insurance

I have enclosed a self-addressed, stamped envelope for your convenience. If you have any questions, please contact me at 315-752-1180. Ext. 501.

Sincerely,

Tracy M. Cosilmon
Town Clerk

Enclosures
file

RECEIVED

OCT 29 2025

Village of North Syracuse

ORIGINAL

THIS AGREEMENT made and entered into as of the 1st day of January, 2026, by and between the TOWN BOARD OF THE TOWN OF CICERO, Onondaga County, New York, acting for and on behalf of the NORTH SYRACUSE FIRE PROTECTION DISTRICT (hereinafter "Town"); the VILLAGE BOARD OF TRUSTEES of the VILLAGE OF NORTH SYRACUSE, Onondaga County, New York (hereinafter called the "Village") and the NORTH SYRACUSE VOLUNTEER FIREFIGHTERS' ASSOCIATION (hereinafter "Association");

WHEREAS, there has been duly established in the said Town of Cicero, a Fire Protection District, known as NORTH SYRACUSE FIRE PROTECTION DISTRICT, embracing part of the territory in said Town, outside of existing incorporated Villages and Fire Districts. The district boundaries are more modernly depicted on the Boundary Map described on "Exhibit A" attached hereto and labeled accordingly; and

WHEREAS, following a public hearing duly called the Town, the Town has authorized this contract with the Village for fire protection as hereinafter set forth.

NOW, THEREFORE, the Town does hereby engage the Village to furnish fire protection in such territory in the said North Syracuse Fire Protection District as herein designated by the Town, and the Village agrees to furnish such protection in the manner following:

1. The fire department of the Village shall, at all times during the period of this Agreement, be subject to call for attendance upon any fire or emergency occurring in the North Syracuse Fire Protection District, and when notified by alarm or telephone call from any person within the said Fire Protection District of a fire or emergency the Village fire department shall respond and attend upon the fire or emergency without unnecessary delay with suitable equipment and a sufficient number of volunteer firefighters, and upon arriving at the scene of the fire or emergency, shall proceed with diligence in the extinguishments of such fire or render necessary aid appropriate to the emergency.
2. The Village fire department shall, at all times during the term of this Agreement, participate in the Onondaga County Mutual Aid program of fire protection.
3. The term of this Agreement is from January 1, 2026 to December 31, 2026.
4. In consideration of furnishing aid and the use of its apparatus as aforesaid, the Village shall receive the sum, payable on or before March 1, 2026 of Two Hundred and Eighty One Thousand and Six Hundred and Thirty Two and No/100 Dollars (\$281,632.00) for the period January 1, 2026 through and including December 31, 2026.

In addition to said contract amount, the Town agrees to pay to the Village up to the sum of Sixty Six Thousand Six Hundred and Sixty Seven and No/100 Dollars (\$66,667.00), representing the Town's portion of the contribution to the Length of Service Awards Program. An amount not to exceed \$56,326.00 shall be paid separately to North Syracuse Volunteer Firefighters' Association.

5. Members of the Village fire department, while engaged in the performance of their duties in answering, attending upon or returning from any call provided for by this Agreement shall have the same rights, privileges and immunities as if performing the same in the Village.
6. All monies to be paid under any provision of this Agreement shall be charged upon the said Fire Protection District to be assessed and levied upon the taxable property in the Town of Cicero Fire Protection District and collected with the Town taxes.
7. The Village shall obtain insurance coverage as hereinafter set forth and shall furnish to the Town Certificates of Insurance that such insurance is in effect for the contract period. In addition thereto, the Town shall be named as an additional insured on said policies. The Village shall provide Worker's Compensation and Employer's Liability Insurance, including disability benefits as required by law. Comprehensive General Liability, including premises, completed operation, broad form property damage and broad form contractual will be provided for each accident therefrom, as well as adequate provision for property. The policy so provided shall include an endorsement that the Town will be notified by registered mail, 15 business days prior to any changes or cancellation of any policy.
8. The Village agrees to indemnify, defend and hold the Town of Cicero, its officers, directors, agents, employees and other related parties harmless from and against any and all liabilities, damages, losses, expenses, claims, demands, suits, fines, or judgments that include reasonable attorneys' fees, costs and expenses, incidental thereto, which may be suffered by, accrued against, charges to or recoverable from the Town, by reason of any claim arising out of or relating to any act or error or omission, or misconduct of the Department, its officers, directors, agents, employees, volunteers or subcontractors.
9. The Town of Cicero, at its own expense, may request and conduct a review of the books, assets and expenses of the Firefighters' Association and the Village of North Syracuse upon reasonable notice.
10. Notwithstanding anything to contrary herein, the Town shall have the option to terminate this agreement at the end of any calendar year as specified herein, in the event that the Town creates fire districts, undertakes a consolidation of existing Fire Protection Districts, or undertakes a modification of Fire Protection District boundaries, any of which actions affect the territorial limits of the boundaries of the North Syracuse Fire Protection District. The Town shall give at least ninety (90) days' notice of its intent to exercise such option.

IN WITNESS WHEREOF, the parties hereto have executed this Agreement the day and year first above written.

TOWN BOARD OF THE TOWN OF CICERO

By:

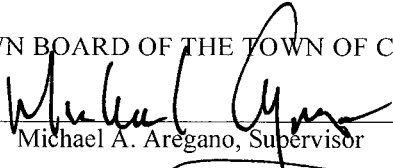
Michael A. Aregano, Supervisor

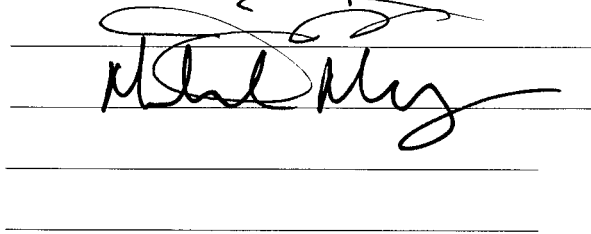

Town Board

Attest:

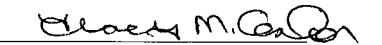

Tracy M. Cosilmon, Town Clerk

[signatures continue on following page]

VILLAGE OF NORTH SYRACUSE ONONDAGA
COUNTY, NEW YORK

By: *Jay Buettyger*
Mayor

Attest:

Village Clerk

NORTH SYRACUSE VOLUNTEER
FIREFIGHTERS' ASSOCIATION
ONONDAGA COUNTY, NEW YORK

By: _____
President

North Syracuse Volunteer Fire Department

By: _____
Chief

Voucher

TOWN OF CICERO

8236 Brewerton Road
Cicero, New York 13039

TAX ID No. 15-6000898
(315) 699-2759

W-9

Claimant's Name and Address

 North Syracuse Volunteer Firefighters' Association

PLEASE DO NOT
WRITE IN THIS AREA

Voucher No. _____

Date Voucher Received _____

Fund-Appropriation	Amount
065-3410-4000-0000	
Total	56,326.00
Entered on Abstract No. _____	

PURCH
TERMS _____

Detailed invoices may be attached and total entered on this Voucher. Certification below MUST BE SIGNED

Date	Vendor's Invoice No.	Quantity	Description of Materials or Services	Unit Price	Amount
10/23/2025			2026 Town of Cicero Village of North Syracuse Fire Protection District Agreement Cicero Town Board Approved October 22, 2025		
Total					\$56,326.00

Claimant's Certification

I, _____, certify that the above account in the amount of \$ _____ is true and correct; that the items, services and disbursements charged were rendered to or for the municipality on the dates stated; that no part has been paid or satisfied; that taxes, from which the municipality is exempt, are not included; and that the amount claimed is actually due.

Date

Signature

Title

(Space below for Municipal Use)

Department Approval

The above services or materials were rendered or furnished to the Municipality on the date stated and the charges are correct.

Approval For Payment

This claim is approved and ordered paid from the appropriations indicated above.

Date

Authorized Official

Voucher

TOWN OF CICERO

8236 Brewerton Road
Cicero, New York 13039

TAX ID No. 15-6000898
(315) 699-2759

W-9

Claimant's Village of North Syracuse

Name and Attn: Mayor Butterfield

Address 600 S, Bay Road

North Syracuse, NY 13212

PLEASE DO NOT
WRITE IN THIS AREA

Voucher

No. _____

Date Voucher Received _____

Fund-Appropriation	Amount
065-3410-4000-0000	
	281,632.00
Service Award Program	66,667.00
Total	348,299.00
Entered on Abstract No. _____	

PURCH
TERMS _____

Detailed invoices may be attached and total entered on this Voucher. Certification below MUST BE SIGNED

Date	Vendor's Invoice No.	Quantity	Description of Materials or Services	Unit Price	Amount
10/23/2025			2026 FIRE PROTECTION CONTRACT January 1, 2026-December 31, 2026		\$281,632.00
			Length of Service Award (LOSAP)		\$66,667.00
			Cicero Town Board Approved 22-Oct-25		
					\$348,299.00

Claimant's Certification

I, _____, certify that the above account in the amount of \$ _____ is true and correct; that the items, services and disbursements charged were rendered to or for the municipality on the dates stated; that no part has been paid or satisfied; that taxes, from which the municipality is exempt, are not included; and that the amount claimed is actually due.

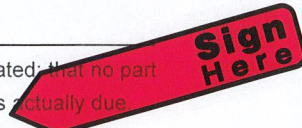

Date

Signature

Title

(Space below for Municipal Use)

Department Approval

The above services or materials were rendered or furnished to the Municipality on the date stated and the charges are correct.

_____ Date

_____ Authorized Official

Approval For Payment

This claim is approved and ordered paid from the appropriations indicated above.

Sancomb's Electrical Services

(Invoice-Receipt)

890 Herlihy Road
Tully, N.Y. 13159

Phone: 315-263-8970
Email: woodsrunner67@aol.com
Fax: 315-683-9290

Bill To

Gill Steven's

Invoice # 11535 Date 03-05-2026 Terms On Receipt
Account #

Description	Rate	Amount
Job Quote for - North Syracuse Dept. of Public Works 106 Ferguson Ave. Syracuse, N.Y. 13212 *Unhook old Generac generator and removed *Installed new quite connect cummin's stand by generator series RS13KW with 200 amp automatic transfer switch *Run new gas line and hook up to new generator 1/2 Down = \$6,900.00 \$6,900.00 on Completion Labor and Material	1	\$13,800.00

Subtotal \$13,800.00
Tax \$0.00
Total \$13,800.00
Balance Due \$13,800.00

PAST DUE

Sancomb's Electrical Services

Invoice-Receipt

890 Herlihy Road
Tully, N.Y. 13159

Phone:315-263-8970
Email: woodsrunner67@aol.com
Fax: 315-683-9290

Bill To

Gill Steven's

Invoice # 11535
Account #

Date 03-05-2026

Terms On Receipt

Description	Rate	Amount
Job Quote for - North Syracuse Dept. of Public Works 106 Ferguson Ave. Syracuse, N.Y. 13212 *Unhook old Generac generator and removed *Installed new quite connect cummin's stand by generator series RS17KW with 200 amp automatic transfer switch *Run new gas line and hook up to new generator 1/2 Down = \$7,350.00 \$7,350.00 on Completion Labor and Material	1	\$14,700.00

Subtotal **\$14,700.00**
Tax **\$0.00**
Total **\$14,700.00**
Balance Due **\$14,700.00**

FAB 03/05/26

SPECIFICATION SHEET

QUIET CONNECT™

Series RS13A, RS17A,
RS20A, RS20AC

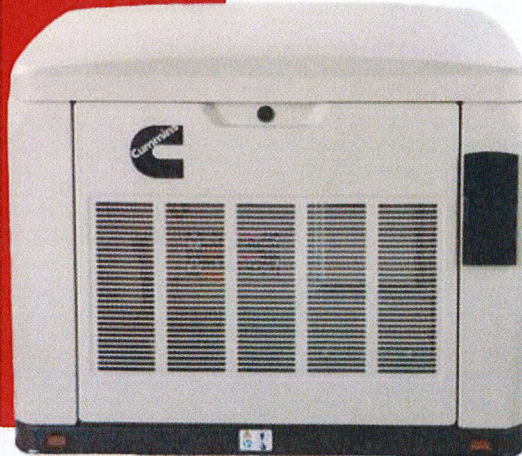

Features and Benefits

Robust Design – The generator is designed to operate in cold weather with performance down to 0 °F (-18 °C) out of the box. The extreme cold weather models can perform down to -40 °F (-40 °C) out of the box. It is tested and certified per the latest EPA, UL, and CSA standards. The generator meets NFPA 37 which allows it to be installed 18 inches from a building. It has powerful motor starting ability and can easily start and run a 5-ton A/C¹ under full pre-load.

Intelligent Load Management - The generator can control up to 4 loads and continuously monitors how much power is required independently for each load. It then controls each load for maximum utilization of generator power by only restoring loads the generator has capacity to run.

Flexible Exercise Modes - Exercise modes can be set for time, date, and frequency that suits the owner. Our patented 'Crank only' exercise mode allows the generator to crank the engine and run diagnostics without starting the engine. This reduces wear and tear on the engine, fuel costs, and further reduces the sound of an already quiet generator.

Remote Monitoring - Remote monitoring is built into every generator. Using a computer, tablet, or smart phone, an operator can monitor, change exercise modes, and manually run the generator remotely.

Generator and ATS packaged sets – The RS20AC comes with a 20-kW generator and 200A service entrance rated ATS in one box to make ordering more convenient.

Weight, Size, and Sound Level

Size: Length: 34.1 in (865 mm), Width: 36.0 in (915 mm), Height: 27.3 in (694 mm)

Sound: 65 dB(A) at 23 ft. (7 m) at normal load²

Voltage / Frequency: 120/240V / 60Hz

Series	Model	Part number	Extreme Cold Weather	Rated amp ³ (NG / LPV)	Weight Lbs. / Kg
RS13A	C13N6H	A071Z390	No	54.2 / 54.2	479 / 217
RS17A	C17N6H	A071Z394	No	70.8 / 70.8	531 / 241
RS20A	C20N6H	A071Z397	No	75 / 83.3	531 / 241
RS20AC	C20N6HC	A071Z402	No	75 / 83.3	596 / 271
RS13AE	C13N6H	A071Z407	Yes	54.2 / 54.2	479 / 217
RS17AE	C17N6H	A071Z401	Yes	70.8 / 70.8	531 / 241
RS20AE	C20N6H	A071Z202	Yes	75 / 83.3	531 / 241
RS20ACE	C20N6HC	A071Z395	Yes	75 / 83.3	596 / 271

¹ Air-conditioners vary by type, operational conditions, etc. Consult with a qualified Cummins Power Generation dealer for proper sizing.

² Quietest point at a normal load. Sound performance may be affected by installation.

³ Derating guidelines: Maximum wattage or maximum current are subject to and limited by such factors as fuel Btu content, ambient temperature, altitude, engine power and condition, etc. Full rated power available up to the following, derate 3.5% for each increase of 300 m (1000 ft.) and 1% for each increase of 5.5 °C (10 °F) after that:

RS20A & R20AC – at 15 °C (60 °F) and 0 m (0 ft.).

RS17A – at 25 °C (77 °F) and 300 m (1000 ft.)

RS13A – at 25 °C (77 °F) and 2100 m (6900 ft.)

Product Features

Engine

- Natural gas/propane
- Engine air cleaner
- Engine oil (Synthetic)
- Oil drain extension tube
- Low oil pressure shutdown

Fuel System

- Single fuel – natural gas or propane vapor, field selectable (Set to Natural gas from factory)

Alternator

- 60 Hz, 1 phase, < 5% THD (total harmonic distortion)
- Long life electrographic DC brushes
- Slip ring heater

Control

- Display language – English
- Under hood built in display

Electrical

- Single 100A circuit breaker, UL certified (On all models)
- Battery charging alternator
- Battery charger – 4 Amps

Cooling

- Single direct drive blower

Enclosure

- Aluminum exterior, galvanized steel interior
- Evaluated to withstand 180 mph wind loads in accordance with ASCE7-10

Code Compliance

- UL 2200
- CSA 22.2 and B149.1
- EPA emissions
- NFPA 37 – 18 inches

Warranty

Base: 5 years / 2000 hours

Extended warranties available

Generator Set performance

Voltage regulation, no load to full load: ±1.25%

Steady state voltage variation: ±1.25%

Frequency regulation: Isochronous

Motor starting kVA (30% voltage dip): 40 for RS20A/AC, 34 for RS17A, and 26 for RS13A

Steady state freq. variation: ±1.25% (±1.5% @ No load)

Operating temperature: 122 °F (50 °C) to -40 °F (-40 °C)

See Accessories section for details on kits

Engine Specifications

Model: QSJ999G

Design: Naturally aspirated, V twin air cooled

Bore: 3.54 in (89.9 mm)

Stroke: 3.09 in (78.5 mm)

Displacement: 60.96 inch³ (999 CC)

Cylinder block: Aluminum

Battery capacity: Group 51R, 450 CCA at ambient temperature of 32 °F (0 °C)

Starting voltage: 12 Volt, negative ground

Oil Filter type: Spin-on

Rated speed: 3600 rpm

Fuel Supply Pressure

Minimum - in H₂O (kPa):

NG - 3.5 (0.87) / LP - 6.0 (1.49)

Maximum - in H₂O (kPa):

NG - 10.0 (2.5) / LP - 10.0 (2.5)

Typical Fuel Consumption

RS13A Fuel consumption – natural gas

Load:	1/4	1/2	3/4	Full
ft ³ / hr.	129	154	187	228
m ³ / hr.	3.7	4.4	5.3	6.5
BTU / hr.	123028	146534	178640	217227

RS13A Fuel consumption – LP vapor

Load:	1/4	1/2	3/4	Full
ft ³ / hr.	42	51	64	83
m ³ / hr.	1.2	1.4	1.8	2.3
BTU / hr.	98852	121723	152253	197681

RS17A Fuel consumption – natural gas

Load:	1/4	1/2	3/4	Full
ft ³ / hr.	134	165	215	258
m ³ / hr.	3.8	4.7	6.1	7.3
BTU / hr.	127745	157870	205464	245954

RS17A Fuel consumption – LP vapor

Load:	1/4	1/2	3/4	Full
ft ³ / hr.	48	63	82	102
m ³ / hr.	1.4	1.8	2.3	2.9
BTU / hr.	114082	148026	194392	242386

RS20A & RS20AC Fuel consumption – natural gas

Load:	1/4	1/2	3/4	Full
ft ³ / hr.	135	172	223	268
m ³ / hr.	3.8	4.9	6.3	7.6
BTU / hr.	128822	163890	212731	255947

RS20A & RS20AC Fuel consumption – LP vapor

Load:	1/4	1/2	3/4	Full
ft ³ / hr.	49	66	88	112
m ³ / hr.	1.4	1.9	2.5	3.2
BTU / hr.	117208	157482	209404	265783

Nominal fuel rating – 1000 BTU / ft³ (37 MJ / M³)

Conversion factor:

8.58 ft³ = 1 lb.

0.535m³ = 1 kg

36.39 ft³ = 1 gal

1.02m³ = 1 gal (LPG)

Easy Service and Installation

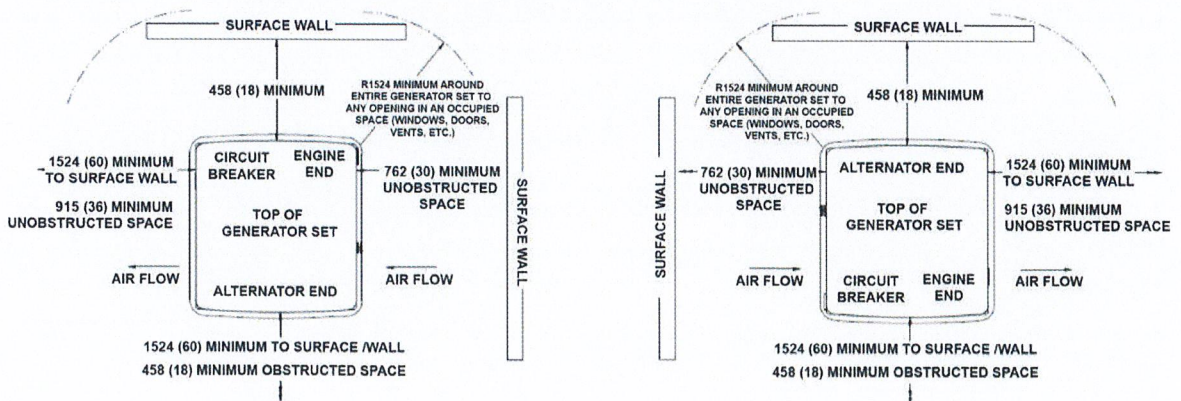
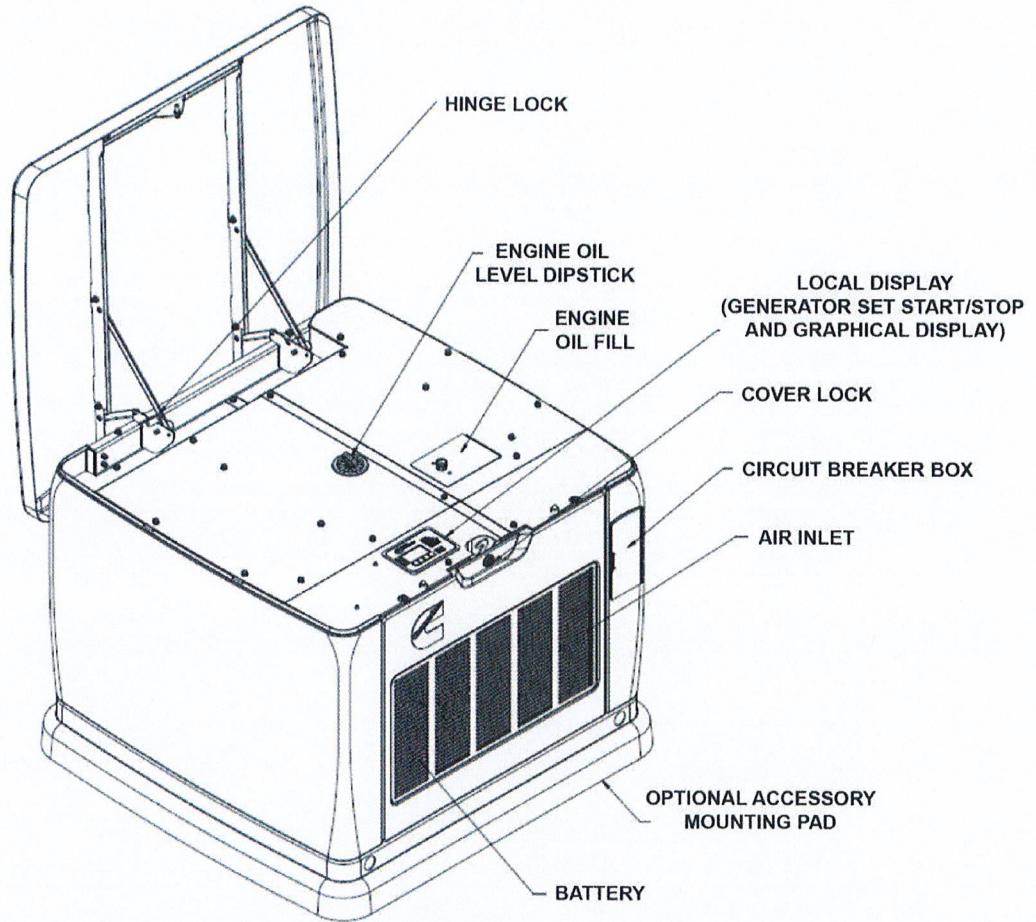

Basic Dimension

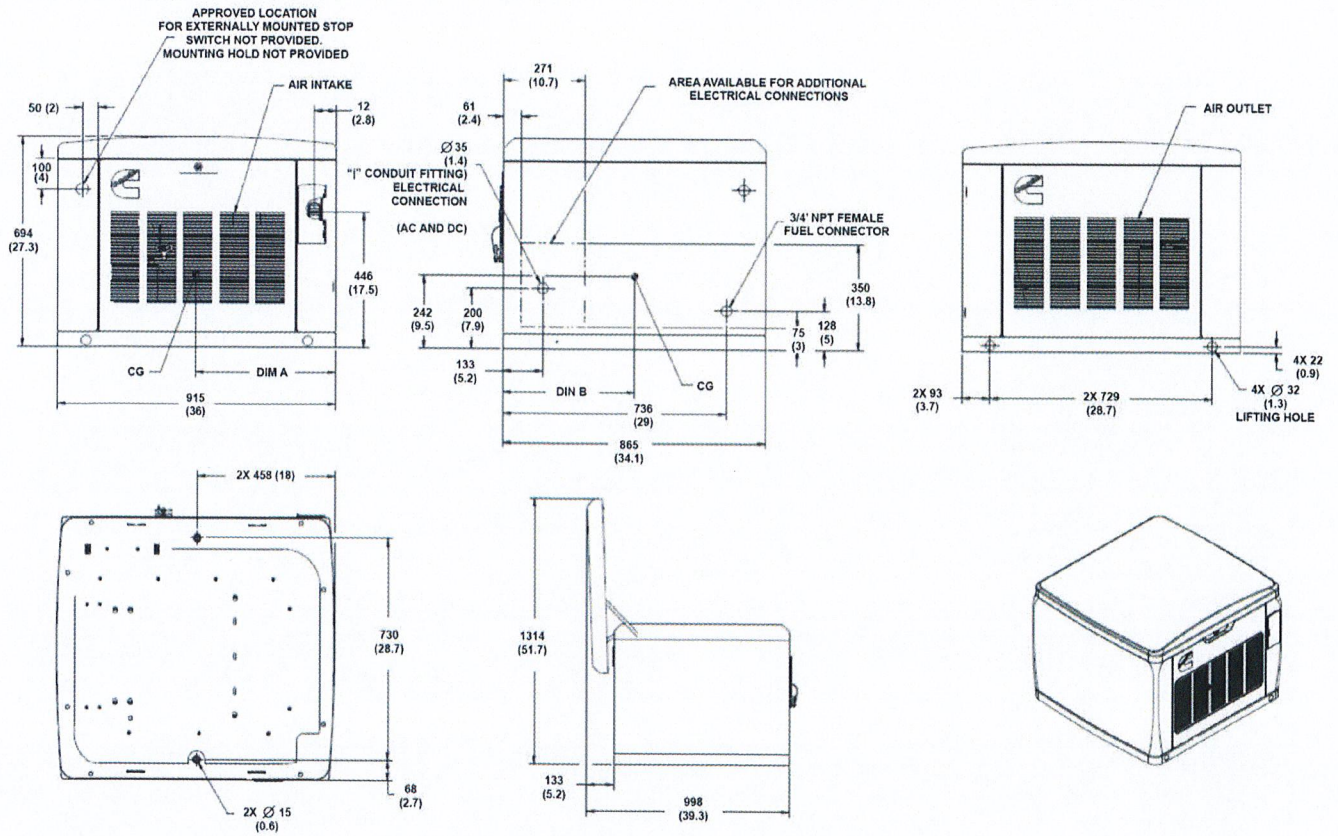

Note: This outline drawing provides general reference only and is not intended for use in design or installation. For more information, see Operators and Installation manuals or contact your dealer for assistance.

Accessories

- RS In-home display (A053K028) - Additional interface and display to monitor generator performance from a second location.
- Extreme Cold Weather Kit (A054B984) – For locations where the generator will be in climates that can go below 0 °F (-18 °C). Not needed on extreme cold weather models.
- Enclosure Paint Touchup Kit (A043J735)
- Preventative Maintenance Kit (A054H068) – Parts for scheduled maintenance intervals
- Load Add/Load Shed Device (A051C329) – Allows generator to control up to 2 - 50A loads
- Integrated ATS & Load Panel (A051C991) – Combines an 100A Non-Service Entrance (NSE) ATS with a load panel in an NEMA 1 box. (Refer to NAS-6287)
- Concrete Composite Mounting Pad - 3" thick, 1" overhang composite pad for mounting the generator on (A052A795 for a single pad and A057M349 for 5 pads).
- E-stop Kit (A044Z051) - Externally mounted emergency stop button allows for additional safety
- Battery (A052Y816) - Group 51R, 450 CCA.



⚠ WARNING:

Standby rating based on: Applicable for supplying emergency power for the duration of normal power interruption. No sustained overload capability is available for this rating. (Equivalent to fuel stop power in accordance with ISO3046, AS2789, DIN6271 and BS5514 nominally rated.) See T030.

⚠ WARNING:

Back feed to a utility system can cause electrocution and/or property damage. Do not connect to any building electrical except through an approved device or after building main breaker is open.

Transfer Switch (sold separately)

- Automatic Transfer Switches available at various amperages. (Refer to NAS-5810-EN, A-1568, S-1639)
- Service Entrance and Non-Service Entrances models are available.
- Available for both Indoor and Outdoor applications.
- All models listed to UL 1008 standard.
- Compatibility with the Cummins generator set helps reduce the installation time for the complete application.

Warranty Policy

The Cummins Power Generation RS13A, RS17A, RS20A, and RS20AC generators come standard with a 5 year / 2,000 hour limited warranty. RA Automatic Transfer Switches come standard with a 2 year warranty. Extended warranty options available. See warranty statement for additional details.

After Sale Support

Largest dealer support network

Cummins generator sets are supported by the best trained and certified dealer network in the industry. This network of knowledgeable dealers will help you select the right generator for your application and advise you on associated accessories for your generator. Cummins dealers can also help answer any questions you may have regarding operation and maintenance requirements of the generators. Certified dealers also offer a complete selection of commonly used generator set maintenance parts and manuals.

Manuals: Operation and installation manuals ship with the generator set. To obtain additional copies or other manuals for this model, see your dealer. To easily locate the nearest certified dealer for Cummins generators in your area, or for more information, contact us at 1-800-344-0039 or visit power.cummins.com.

Contact your dealer for more information.

Cummins Inc.
Box 3005
Columbus, IN 47202-3005
U.S.A.

1-800-CUMMINS™ (1-800-286-6467)
cummins.com

NAS-6254-EN (5/24)

©2024 Cummins Inc.



Part A059K578 A

Description	Legacy Name	External Regulations	Application Status	Release Phase Code	Security Classification	Alternates
OUTLINE,GENSET	A059K578	No External Regulations Apply	Production Only	Production	Confidential	

Part Specifications : A059K578 A

Name	Description	Legacy Name
A030B356	SPECIFICATION,MATERIAL	CES I0903
A059K579	DRAWING,ENGINEERING	A059K579

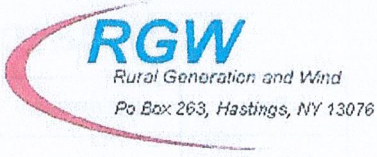

Estimate

Date	Estimate #
3/12/2026	1131

Name / Address
Village of North Syracuse 106 Ferguson Ave North Syracuse, NY 13212

Ship To
DPW Building

P.O. No.

Due Date	Term	Rep	Project
3/12/2026			

Item	Description	Qty	Rate	Total
gen7225	14Kw Air Cooled Generac Generator, Alum Enclosure will be installed to the existing select circuit transfer switch. Work to be performed as follows: Disconnect the gas piping from the old 12kw generator that is there Disconnect the existing wiring from the old generator Taking out the old generator and hauling it away Replacing it with a new Generac 14kw Generator, natural gas Taking the old wiring that was there all the way back to the select circuit transfer switch and taking it out because the conduit that is there is not rated for outdoors and not per NEC code Replacing the wire from the generator back to the transfer switch with NEMA 4 wiring made for outside and secured to the concrete block wall Putting in a new battery Price includes the additional wiring from the generator to the transfer switch	1	10,800.00	10,800.00T

QUOTE IS VALID FOR 15 DAYS. THANK YOU FOR THE OPPORTUNITY. THERE IS A NO RETURN POLICY.

Subtotal
Sales Tax (0.0%)
Total

CUSTOMER IS RESPONSIBLE FOR GETTING ALL OR ANY PERMITS FOR THE INSTALLATION OF THE GENERATOR, WIND TURBINE, PV SOLAR, SOLAR THERMAL FOR YOUR AREA. ALSO, FOR ANY INSPECTIONS THAT ARE NEEDED IS THE CUSTOMER'S RESPONSIBILITY. RURAL GENERATION AND WIND IS NOT RESPONSIBLE FOR ANY DELAYS IN SHIPPING CREATED BY THE MANUFACTURER. FREIGHT/SHIPPING CHARGES ARE SUBJECT TO CHANGE BASED ON COST AT TIME OF SHIPPING. IF USING A CREDIT CARD, THERE WILL BE A CONVENIENCE FEE OF 4% ADDED.

Signature _____

Phone #	Fax #	E-mail	Web Site
315-668-7537	888-208-5054	rodney@ruralgenerationandwind.net	ruralgenerationandwind.net

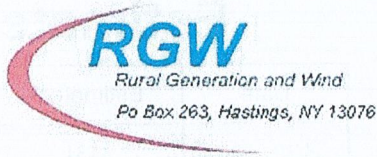

Estimate

Date	Estimate #
3/12/2026	1131

Name / Address
Village of North Syracuse 106 Ferguson Ave North Syracuse, NY 13212

Ship To
DPW Building

P.O. No.

Due Date
3/12/2026

Terr Rep

Project

Item	Description	Qty	Rate	Total
GAS PIPING	NATURAL GAS PIPING - The natural gas piping that is to the generator currently is against code and needs to be replaced with black iron. This cost will include taking out the old piping, and replacing it with 1" black iron pipe with gas valve at the generator all the way back to the point inside the garage where the old generator gas pipe is connected to	1	900.00	900.00T
genwarranty	The generator has a 7 year manufacturers warranty. RGW has a lifetime of any or all workmanship performed by RGW. We are a certified dealer for Generac for service, installation and warranty. RGW offers 24 hour emergency service.		0.00	0.00T

QUOTE IS VALID FOR 15 DAYS. THANK YOU FOR THE OPPORTUNITY. THERE IS A NO RETURN POLICY.

CUSTOMER IS RESPONSIBLE FOR GETTING ALL OR ANY PERMITS FOR THE INSTALLATION OF THE GENERATOR, WIND TURBINE, PV SOLAR, SOLAR THERMAL FOR YOUR AREA. ALSO, FOR ANY INSPECTIONS THAT ARE NEEDED IS THE CUSTOMER'S RESPONSIBILITY. RURAL GENERATION AND WIND IS NOT RESPONSIBLE FOR ANY DELAYS IN SHIPPING CREATED BY THE MANUFACTURER. FREIGHT/SHIPPING CHARGES ARE SUBJECT TO CHANGE BASED ON COST AT TIME OF SHIPPING. IF USING A CREDIT CARD, THERE WILL BE A CONVENIENCE FEE OF 4% ADDED.

Subtotal
Sales Tax (0.0%)
Total

Signature _____

Phone #	Fax #	E-mail	Web Site
315-668-7537	888-208-5054	rodney@ruralgenerationandwind.net	ruralgenerationandwind.net

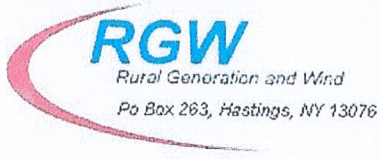

Estimate

Date	Estimate #
3/12/2026	1131

Name / Address
Village of North Syracuse 106 Ferguson Ave North Syracuse, NY 13212

Ship To
DPW Building

P.O. No.

Due Date	Term	Rep	Project
3/12/2026			

Item	Description	Qty	Rate	Total
Down Payment 1	We would require a down payment \$7000.00 down and the remaining balance is due upon completion of our work and has nothing to do with the propane company, timeline or when they hook up. We are to be paid once our work is complete. If propane is not hooked up while we are there, we will come back to start generator up and go over it. Remaining balance is due once our work is complete. We do not wait for the propane company and our monies is not held until the propane shows up.		0.00	0.00T
YEARLY SERVI...	YEARLY SERVICE ON YOUR GUARDIAN/GENERAC GENERATOR CONSTISTS OF: CHECKING OR TESTING :FUEL PRESSURE & BATTERY VOLTAGE. CHANGE OIL FILTER,NEW OIL,AIR FILTER,SPARK PLUGS. CHECK OR TEST VALVE ADJUSTMENT,VOLTAGE ADJUSTMENT,HZ ADJUSTMENT The cost for this is 215.00 per each yearly service.			0.00T

QUOTE IS VALID FOR 15 DAYS. THANK YOU FOR THE OPPORTUNITY. THERE IS A NO RETURN POLICY.

CUSTOMER IS RESPONSIBLE FOR GETTING ALL OR ANY PERMITS FOR THE INSTALLATION OF THE GENERATOR,WIND TURBINE, PV SOLAR, SOLAR THERMAL FOR YOUR AREA. ALSO, FOR ANY INSPECTIONS THAT ARE NEEDED IS THE CUSTOMER'S RESPONSIBILITY. RURAL GENERATION AND WIND IS NOT RESPONSIBLE FOR ANY DELAYS IN SHIPPING CREATED BY THE MANUFACTURER. FREIGHT/SHIPPING CHARGES ARE SUBJECT TO CHANGE BASED ON COST AT TIME OF SHIPPING. IF USING A CREDIT CARD, THERE WILL BE A CONVENIENCE FEE OF 4% ADDED.

Subtotal	\$11,700.00
Sales Tax (0.0%)	\$0.00
Total	\$11,700.00

Signature _____

Phone #	Fax #	E-mail	Web Site
315-668-7537	888-208-5054	rodncy@ruralgenerationandwind.net	ruralgenerationandwind.net

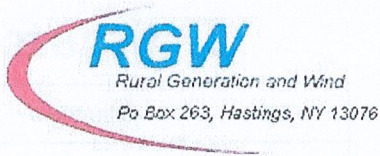

Estimate

Date	Estimate #
3/12/2026	1131

Name / Address
Village of North Syracuse 106 Ferguson Ave North Syracuse, NY 13212

Ship To
DPW Building

P.O. No.

Due Date	Term	Rep	Project
3/12/2026			

Item	Description	Qty	Rate	Total
gen7225	<p>14Kw Air Cooled Generac Generator, Alum Enclosure will be installed to the existing select circuit transfer switch.</p> <p>Work to be performed as follows: Disconnect the gas piping from the old 12kw generator that is there Disconnect the existing wiring from the old generator Taking out the old generator and hauling it away Replacing it with a new Generac 14kw Generator, natural gas Taking the old wiring that was there all the way back to the select circuit transfer switch and taking it out because the conduit that is there is not rated for outdoors and not per NEC code Replacing the wire from the generator back to the transfer switch with NEMA 4 wiring made for outside and secured to the concrete block wall Putting in a new battery Price includes the additional wiring from the generator to the transfer switch</p>	1	10,800.00	10,800.00

QUOTE IS VALID FOR 15 DAYS. THANK YOU FOR THE OPPORTUNITY. THERE IS A NO RETURN POLICY.	Subtotal
CUSTOMER IS RESPONSIBLE FOR GETTING ALL OR ANY PERMITS FOR THE INSTALLATION OF THE GENERATOR, WIND TURBINE, PV SOLAR, SOLAR THERMAL FOR YOUR AREA. ALSO, FOR ANY INSPECTIONS THAT ARE NEEDED IS THE CUSTOMER'S RESPONSIBILITY. RURAL GENERATION AND WIND IS NOT RESPONSIBLE FOR ANY DELAYS IN SHIPPING CREATED BY THE MANUFACTURER. FREIGHT/SHIPPING CHARGES ARE SUBJECT TO CHANGE BASED ON COST AT TIME OF SHIPPING. IF USING A CREDIT CARD, THERE WILL BE A CONVENIENCE FEE OF 4% ADDED.	Sales Tax (0.0%)
	Total

Signature _____

Phone #	Fax #	E-mail	Web Site
315-668-7537	888-208-5054	rodney@ruralgenerationandwind.net	ruralgenerationandwind.net

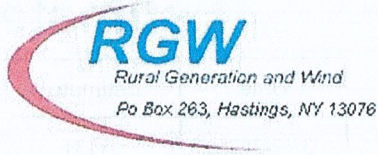

Estimate

Date	Estimate #
3/12/2026	1131

Name / Address
Village of North Syracuse 106 Ferguson Ave North Syracuse, NY 13212

Ship To
DPW Building

P.O. No.

Due Date	Term	Project
3/12/2026		

Item	Description	Qty	Rate	Total
GAS PIPING	NATURAL GAS PIPING - The natural gas piping that is to the generator currently is against code and needs to be replaced with black iron. This cost will include taking out the old piping, and replacing it with 1" black iron pipe with gas valve at the generator all the way back to the point inside the garage where the old generator gas pipe is connected to	1	900.00	900.00T
genwarranty	The generator has a 7 year manufacturers warranty. RGW has a lifetime of any or all workmanship performed by RGW. We are a certified dealer for Generac for service, installation and warranty. RGW offers 24 hour emergency service.		0.00	0.00T

QUOTE IS VALID FOR 15 DAYS. THANK YOU FOR THE OPPORTUNITY. THERE IS A NO RETURN POLICY.

CUSTOMER IS RESPONSIBLE FOR GETTING ALL OR ANY PERMITS FOR THE INSTALLATION OF THE GENERATOR, WIND TURBINE, PV SOLAR, SOLAR THERMAL FOR YOUR AREA. ALSO, FOR ANY INSPECTIONS THAT ARE NEEDED IS THE CUSTOMER'S RESPONSIBILITY. RURAL GENERATION AND WIND IS NOT RESPONSIBLE FOR ANY DELAYS IN SHIPPING CREATED BY THE MANUFACTURER. FREIGHT/SHIPPING CHARGES ARE SUBJECT TO CHANGE BASED ON COST AT TIME OF SHIPPING. IF USING A CREDIT CARD, THERE WILL BE A CONVENIENCE FEE OF 4% ADDED.

Subtotal

Sales Tax (0.0%)

Total

Signature _____

Phone #	Fax #	E-mail	Web Site
315-668-7537	888-208-5054	rodney@ruralgenerationandwind.net	ruralgenerationandwind.net

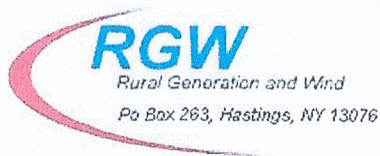

Estimate

Date	Estimate #
3/12/2026	1131

Name / Address
Village of North Syracuse 106 Ferguson Ave North Syracuse, NY 13212

Ship To
DPW Building

P.O. No.

Due Date	Term	Project
3/12/2026		

Item	Description	Qty	Rate	Total
Down Payment 1	We would require a down payment \$7000.00 down and the remaining balance is due upon completion of our work and has nothing to do with the propane company, timeline or when they hook up. We are to be paid once our work is complete. If propane is not hooked up while we are there, we will come back to start generator up and go over it. Remaining balance is due once our work is complete. We do not wait for the propane company and our monies is not held until the propane shows up.		0.00	0.00T
YEARLY SERV...	YEARLY SERVICE ON YOUR GUARDIAN/GENERAC GENERATOR CONSISTS OF: CHECKING OR TESTING :FUEL PRESSURE & BATTERY VOLTAGE. CHANGE OIL FILTER,NEW OIL,AIR FILTER,SPARK PLUGS. CHECK OR TEST VALVE ADJUSTMENT,VOLTAGE ADJUSTMENT,HZ ADJUSTMENT The cost for this is 215.00 per each yearly service.			0.00T

QUOTE IS VALID FOR 15 DAYS. THANK YOU FOR THE OPPORTUNITY. THERE IS A NO RETURN POLICY.

Subtotal	\$11,700.00
Sales Tax (0.0%)	\$0.00
Total	\$11,700.00

CUSTOMER IS RESPONSIBLE FOR GETTING ALL OR ANY PERMITS FOR THE INSTALLATION OF THE GENERATOR,WIND TURBINE, PV SOLAR, SOLAR THERMAL FOR YOUR AREA. ALSO, FOR ANY INSPECTIONS THAT ARE NEEDED IS THE CUSTOMER'S RESPONSIBILITY. RURAL GENERATION AND WIND IS NOT RESPONSIBLE FOR ANY DELAYS IN SHIPPING CREATED BY THE MANUFACTURER. FREIGHT/SHIPPING CHARGES ARE SUBJECT TO CHANGE BASED ON COST AT TIME OF SHIPPING. IF USING A CREDIT CARD, THERE WILL BE A CONVENIENCE FEE OF 4% ADDED.

Signature _____

Phone #	Fax #	E-mail	Web Site
315-668-7537	888-208-5054	rodncy@ruralgenerationandwind.net	ruralgenerationandwind.net



Billing Address
 Village of North Syracuse
 106 Ferguson ave
 North Syracuse , NY 13212 USA

Commercial Power Systems
 1127 Corporate Drive
 Farmington, NY 14425
 (877) 421-0203

Estimate 135778350
Job 121492
Estimate Date 3/11/2026
Customer PO

Job Address
 Village of North Syracuse
 106 Ferguson ave
 North Syracuse , NY 13212 USA

Estimate Details

Village of North Syracuse - Generac - : 12kw replacement

Service #	Description	Quantity
14kGENrepl	14kW - Generator Replacement	1.00
	<ul style="list-style-type: none"> • Obtain permits from local authorities as needed • Coordinate electrical inspection by independent agency • Submit added load request to Natural Gas utility (meter upgrade may be required) • Equipment shipping from factory to HPS warehouse where it is inspected for damage • Delivery to customer using HPS patented mono-rail transport system and lift cart • Installation of 540 cold cranking amp 26 class battery • Generator to be placed >18" from structure and 5' from openings per building code • Standard site prep includes sod removal, weed barrier, and 3" gravel for leveling and drainage • Commissioning and startup by factory trained technician includes: <ol style="list-style-type: none"> 1. Warranty activation 2. Voltage / frequency calibration 3. Load testing / balancing 4. Program weekly exercise cycle 5. Connect generator to Wi-Fi network 6. Owner's training and approval checklist 7. Generator left in automatic mode ready for the next utility power failure 8. Rework existing electrical installation complete including labor and material per local electrical and town building codes (if needed). This includes adding up to 30' of control wiring from new generator to existing transfer switch for proper compatibility. (A separate price per foot charge will be added if complete new wiring is required from existing transfer switch to new generator). 9. Rework up to 5' of existing black iron dedicated natural gas pipe from gas meter to new generator installed per local gas codes (if needed). (A separate price per foot charge will be added if complete new natural gas raceway is required from gas meter to new generator). 	
CWKgenac	Install Generac air-cooled (9-26kW) battery & oil warmer.	1.00
SALE PMA CPS AC 1V a YR	SALE PMA CPS AC 1V a YR	1.00
i.-7223	Generac 14/14 kW Air-Cooled Standby Generator, Aluminum Enclosure	1.00
	1P 120/240V	

Sub-Total \$11,411.52
Tax \$26.00
Total \$11,437.52

Please remit payment to:
 1127 Corporate Drive
 Farmington, NY 14425

PAYMENT TERMS: You agree to pay 40% of the total contract price as a down payment at the time of contract acceptance. You agree to pay the remainder of the total contract price when the system is tested and fully operational. **INSTALLATION:** CPS will install the equipment listed on this Contract in a workmanlike manner, per all local electrical, plumbing and building codes and per manufactures recommendations. **LIMITED LIABILITY:** CPS has no liability for interruption of service and possible homeowner damage that may occur if supplied equipment fails to function properly. This includes and not limited to, electronic equipment, sump pumps and any other device powered by this generator. No claims for damage will be made against Commercial Power Systems. Customer has acknowledged contracting for only the equipment and services itemized on this agreement. The above prices, specifications and conditions are satisfactory and hereby accepted. CPS is authorized to do work as specified. The owner may cancel this contract until midnight of the third business day which the owner has signed this agreement. Cancellation occurs when written notice of cancellation is given to Commercial Power Systems.



Billing Address
 Village of North Syracuse
 106 Ferguson ave
 North Syracuse , NY 13212 USA

Commercial Power Systems
 1127 Corporate Drive
 Farmington, NY 14425
 (877) 421-0203

Estimate 136083259
Job 121492
Estimate Date 3/18/2026
Customer PO

Job Address
 Village of North Syracuse
 106 Ferguson ave
 North Syracuse , NY 13212 USA

Estimate Details

Village of North Syracuse - Cummins- : 13kw replacement / new 16 circuit ATS

Service #	Description	Quantity
13kCUacSC	13kW - 20 Circuit transfer switch installation <ul style="list-style-type: none"> • Obtain permits from local authorities as needed • Coordinate electrical inspection by independent agency • Equipment shipping from factory to HPS warehouse where it is inspected for damage • Delivery to customer using HPS patented mono-rail transport system and lift cart • Installation of 540 cold cranking amp 26 class battery • Generator to be placed >18" from structure and 5' from openings per building code • Standard site prep includes sod removal, weed barrier, and 3" gravel for leveling and drainage • Installation of automatic transfer switch • Up to 30' electrical wiring from automatic transfer switch to generator • Commissioning and startup by factory trained technician includes: <ol style="list-style-type: none"> 1. Warranty activation 2. Voltage / frequency calibration 3. Load testing / balancing 4. Program weekly exercise cycle 5. Owner's training and approval checklist 6. Generator left in automatic mode ready for the next utility power failure <p>MOST COMMON ELECTRICAL LOADS SUPPORTED BY THIS SOLUTION: (Subject to equipment capacity)</p> <ol style="list-style-type: none"> 1. Furnace 2. Sump pump 3. Fridge 4. Microwave 5. Kitchen Lights 6. Family room (TV) 7. Master bedroom 8. Master Bathroom 9. Garage door opener 10. Internet 11. Well Pump 12. Well Pump <p>*Actual circuits to be selected by customer upon contract signing and verified by electrician at time of installation.</p>	1.00
SALE PMA CPS AC 1V a YR	SALE PMA CPS AC 1V a YR	1.00
i.-A051C991	100A, 240Vac, 2-Pole, NEMA 1 enclosure, 24 Circuit Load Center (For Cummins Connect Series Generators Only)	1.00
i.-A061C591	RS13A-13kW-NG/LPV-Aluminum Enclosure-120/240V	1.00

Sub-Total \$12,632.44
Tax \$26.00
Total \$12,658.44

Please remit payment to:
 1127 Corporate Drive
 Farmington, NY 14425

PAYMENT TERMS: You agree to pay 40% of the total contract price as a down payment at the time of contract acceptance. You agree to

pay the remainder of the total contract price when the system is tested and fully operational. INSTALLATION: CPS will install the equipment listed on this Contract in a workmanlike manner, per all local electrical, plumbing and building codes and per manufactures recommendations. LIMITED LIABILITY: CPS has no liability for interruption of service and possible homeowner damage that may occur if supplied equipment fails to function properly. This includes and not limited to, electronic equipment, sump pumps and any other device powered by this generator. No claims for damage will be made against Commercial Power Systems. Customer has acknowledged contracting for only the equipment and services itemized on this agreement. The above prices, specifications and conditions are satisfactory and hereby accepted. CPS is authorized to do work as specified. The owner may cancel this contract until midnight of the third business day which the owner has signed this agreement. Cancellation occurs when written notice of cancellation is given to Commercial Power Systems.

Hi Gil,

Thank you for taking the time to meet with me and for the opportunity to have **Commercial Power Systems** provide a quote for your building. I appreciate you having us take a look at the project.

Attached is the quote our master electrician prepared for replacing the existing **12kW generator with a 14kW generator**. The proposed 14kW unit includes a **60-amp breaker** and will **reuse the existing gas line, electrical connections, and the current automatic transfer switch (ATS)**.

Please feel free to give me a call if you or your team have any questions about the quote or the scope of work. I would be happy to review everything with you.

Thank you again for the opportunity.

Best regards,
Terrell
Commercial Power Systems

Terrell Mack
Commercial Power Advisor



Direct: 716.446.1892
Generating Peace of Mind in Upstate NY for Over 20 Years
www.HomePowerSystems.net

Re: ATTENTION ; Gil Commercial Power Systems Generator Replacement Quote Village of North Syracuse

From Terrell Mack <tmack@cpsgenerators.com>

Date Wed 3/18/2026 7:40 AM

To Ed Ware <dpw@northsyracuse.ny.org>

 1 attachment (9 KB)

Outlook-vwdmwtwa;

Yes, we do. We are authorized dealers of Kohler and Cummings as well.. we typically quote the smaller size units with Generac. Were you looking to have us quote a brand other than other than Generac?

Terrell Mack
Commercial Power Advisor



Direct: 716.446.1892

Generating Peace of Mind in Upstate NY for Over 20 Years

www.HomePowerSystems.net

From: Ed Ware <dpw@northsyracuse.ny.org>

Sent: Wednesday, March 18, 2026 4:22:15 AM

To: Terrell Mack <tmack@cpsgenerators.com>

Subject: Re: ATTENTION ; Gil Commercial Power Systems Generator Replacement Quote Village of North Syracuse

The question I have do you deal with any other besides Generac . If so please let me know

From: Terrell Mack <tmack@cpsgenerators.com>

Sent: Thursday, March 12, 2026 2:38 PM

To: Ed Ware <dpw@northsyracuse.ny.org>

Subject: ATTENTION ; Gil Commercial Power Systems Generator Replacement Quote Village of North Syracuse



Billing Address
 Village of North Syracuse
 106 Ferguson ave
 North Syracuse , NY 13212 USA

Commercial Power Systems
 1127 Corporate Drive
 Farmington, NY 14425
 (877) 421-0203

Estimate 135778350
Job 121492
Estimate Date 3/11/2026
Customer PO

Job Address
 Village of North Syracuse
 106 Ferguson ave
 North Syracuse , NY 13212 USA

Estimate Details

Village of North Syracuse: 12kw replacement

Service #	Description	Quantity
14kGENrepl	14kW - Generator Replacement	1.00
	<ul style="list-style-type: none"> • Obtain permits from local authorities as needed • Coordinate electrical inspection by independent agency • Submit added load request to Natural Gas utility (meter upgrade may be required) • Equipment shipping from factory to HPS warehouse where it is inspected for damage • Delivery to customer using HPS patented mono-rail transport system and lift cart • Installation of 540 cold cranking amp 26 class battery • Generator to be placed >18" from structure and 5' from openings per building code • Standard site prep includes sod removal, weed barrier, and 3" gravel for leveling and drainage • Commissioning and startup by factory trained technician includes: <ol style="list-style-type: none"> 1. Warranty activation 2. Voltage / frequency calibration 3. Load testing / balancing 4. Program weekly exercise cycle 5. Connect generator to Wi-Fi network 6. Owner's training and approval checklist 7. Generator left in automatic mode ready for the next utility power failure 8. Rework existing electrical installation complete including labor and material per local electrical and town building codes (if needed). This includes adding up to 30' of control wiring from new generator to existing transfer switch for proper compatibility. (A separate price per foot charge will be added if complete new wiring is required from existing transfer switch to new generator). 9. Rework up to 5' of existing black iron dedicated natural gas pipe from gas meter to new generator installed per local gas codes (if needed). (A separate price per foot charge will be added if complete new natural gas raceway is required from gas meter to new generator). 	
SALE PMA CPS AC 1V a YR i.-7223	SALE PMA CPS AC 1V a YR Generac 14/14 kW Air-Cooled Standby Generator, Aluminum Enclosure 1P 120/240V	1.00 1.00

Sub-Total \$10,995.52
Tax \$26.00
Total \$11,021.52

Please remit payment to:
 1127 Corporate Drive
 Farmington, NY 14425

PAYMENT TERMS: You agree to pay 40% of the total contract price as a down payment at the time of contract acceptance. You agree to pay the remainder of the total contract price when the system is tested and fully operational. **INSTALLATION:** CPS will install the equipment listed on this Contract in a workmanlike manner, per all local electrical, plumbing and building codes and per manufactures recommendations. **LIMITED LIABILITY:** CPS has no liability for interruption of service and possible homeowner damage that may occur if supplied equipment fails to function properly. This includes and not limited to, electronic equipment, sump pumps and any other device powered by this generator. No claims for damage will be made against Commercial Power Systems. Customer has acknowledged contracting for only the equipment and services itemized on this agreement. The above prices, specifications and conditions are satisfactory and hereby accepted. CPS is authorized to do work as specified. The owner may cancel this contract until midnight of the third business day which the owner has signed this agreement. Cancellation occurs when written notice of cancellation is given to Commercial Power Systems.

Resignation Letter

Dear Gilbert Stevens,

I am writing to formally resign from my position with the Village of North Syracuse, effective March 25th.

Working for the Village of North Syracuse has truly been a rewarding experience, and it is not an easy decision for me to step away. During my time here, I have been grateful for the opportunity to serve our community and work alongside such dedicated and supportive colleagues. The experiences I have gained and the relationships I have built will stay with me for a long time.

I want to sincerely thank you and the entire team for the guidance, support, and trust you have given me throughout my time here. I have learned so much, both professionally and personally, and I will always appreciate the chance to have been part of this organization.

While I am excited for the next chapter in my life, I am also genuinely sad to be leaving a place and a team that I care about so much. Please know how thankful I am for the opportunities and experiences I've had while working for the Village.

I will do everything I can to ensure a smooth transition over the coming weeks. Thank you again for everything.

Sincerely,
Christian Johnstone

RECEIVED

MAR 11 2026

VILLAGE OF N. SYRACUSE
CLERK/TREASURER *JPW*

To Whom it May Concern:

We have received a resignation letter from Christian Johnstone on 3/11/2026. His last day will be 3/25/2026. He was a very good worker, and will be missed.

That being said we need to replace my position as a CDL Maintenance Worker, and a Laborer 1 position. We need to put hiring out for both positions ASAP, summer is coming.

Deputy Superintendant

Gil Stevens